

# MIURA STEAM BOILER

## INSTALLATION & OPERATION MANUAL

### EX - HIGH EFFICIENCY SERIES

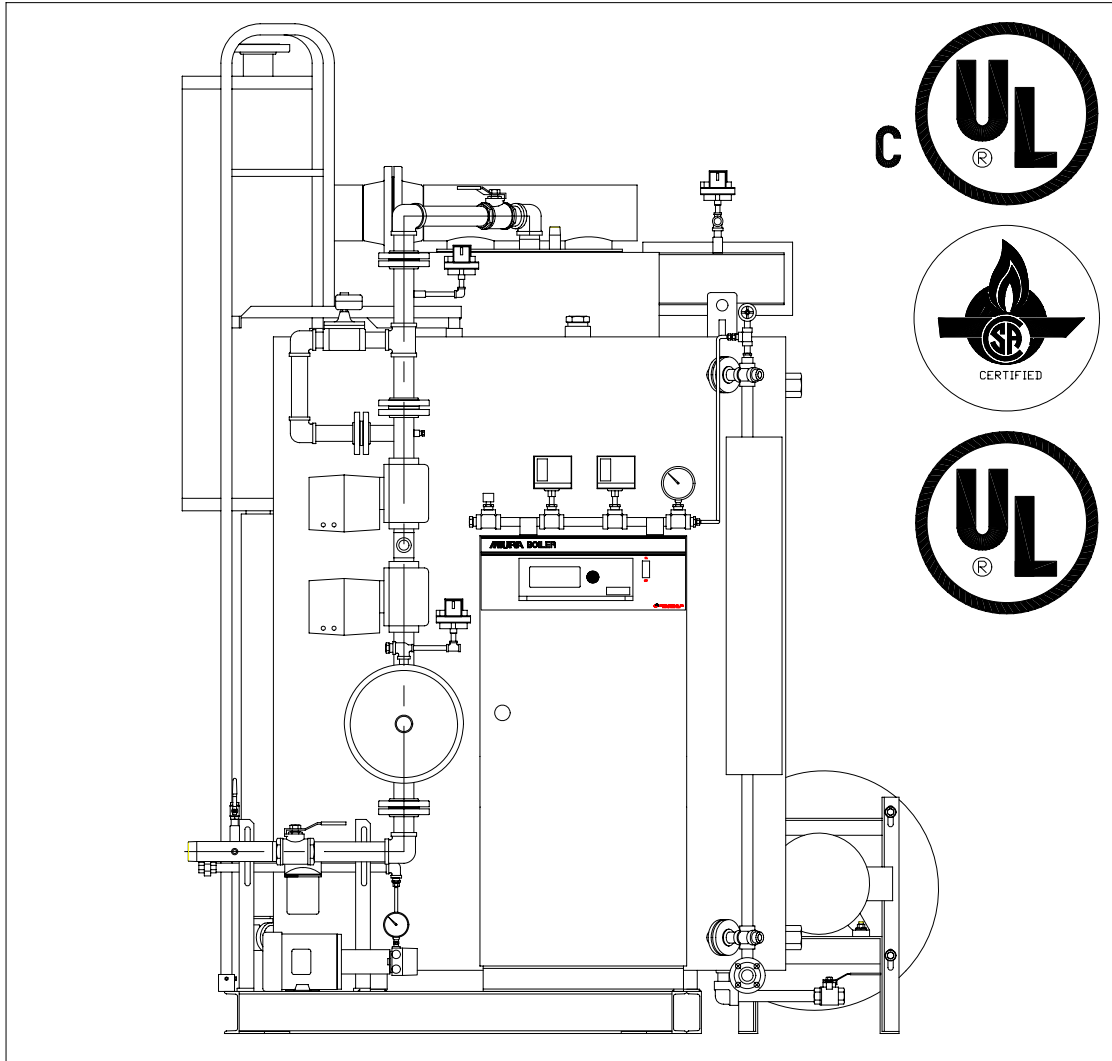

\* INFORMATION IN THIS MANUAL MAY BE CHANGED WITHOUT NOTICE.



MIURA BOILER CO., LTD.  
BRANTFORD, ONTARIO, CANADA

OWNER SHALL MAINTAIN THIS MANUAL IN LEGIBLE CONDITION FOR FUTURE REFERENCE.

Revised 02/27/06

# TABLE OF CONTENTS

<b>SECTION 1</b>	<b><i>Introduction</i></b>	<b><i>1</i></b>
1.1	Definitions and Symbols	1
1.2	Guarantee	1
1.3	Introduction	1
1.4	Features	2
1.5	Description	3
1.6	Specification	7
<b>SECTION 2</b>	<b><i>Acts &amp; Regulations</i></b>	<b><i>16</i></b>
2.1	Acts & Regulations	16
2.2	National Regulatory Organizations	17
<b>SECTION 3</b>	<b><i>Installation</i></b>	<b><i>18</i></b>
3.1	Unloading	18
3.2	Assembling	19
3.3	Steam & Water Piping	21
3.4	Blowdown Piping	27
3.5	Fuel Piping	29
3.6	Clearances & Ventilation	33
3.7	Stacks and Breeching Installation	34
3.8	Electrical installation	37
<b>SECTION 4</b>	<b><i>Operation</i></b>	<b><i>40</i></b>
4.1	Preparation before Start-up	40
4.2	Start-up	40
4.3	Blowdown and Blow-off	41
4.4	Shutdown	42
4.5	Cautions during operation	43
4.6	Safety attachments	44
4.7	Water treatment	47
<b>SECTION 5</b>	<b><i>Maintenance</i></b>	<b><i>50</i></b>
5.1	Maintenance & Cleaning Schedule	50
5.2	Spare parts	51
5.3	Troubleshooting	53
5.4	Flow chart of EX sequence of operation	55

# SECTION 1 INTRODUCTION

## 1.1 DEFINITIONS AND SYMBOLS

Note, Caution and Danger are used throughout this manual with the following definitions and symbols.

**NOTE: Indicates an area or subject of special merit, emphasizing either the product capabilities or common errors in installation, operation or maintenance.**

**CAUTION: Indicates possible damage to equipment. It also indicates any condition or practice, which if not observed or remedied could result in damage or destruction of equipment.**

**DANGER: Indicates any condition or practice, which if not observed, could result in personal injury or possible death.**

## 1.2 GUARANTEE

- Refer to warranty documents for specific details.
- SIX-MONTH labor warranty from boiler start up may be available, contact Local Sales and Service representatives for details. This labor warranty covers routine inspection and repairs at the job site. Travel and lodging expenses are not covered except within local representative service area.
- ONE YEAR Standard warranty for parts from boiler commissioning date or 18 months from shipping date whichever occurs first. Express shipping cost for overnight or next day delivery of parts is not included. Damage to the boiler or parts of the boiler after leaving the factory are not covered. Parts replaced under this warranty must be returned to MIURA. If the failed part is not returned, the customer will be charged for the new item.
- SEVEN-YEAR limited factory warranty on pressure vessel against material or workmanship defects.

## 1.3 INTRODUCTION

Miura Boiler Co., Ltd. began North American activities in 1988, when the manufacturing plant in Brantford, Ontario, was established. Their engineering department developed procedures to meet ASME codes and listing approval from UL, CSA. The United States corporate sales office, Miura Boiler, Inc., was established and has developed relationships with national, state and city inspectors and agencies.

The North American network consists of branches in Chicago, Los Angeles, New York, Atlanta and Ontario. The parent Company, Miura Boiler Ltd. in Japan, is the leading manufacturer of boilers and other thermal equipment in the Pacific Rim holding more than 55% of the market.

With factories in five countries, production now exceeds 14,000 units per year.

As a result of design necessities in Japan, such as limited space and total dependence on foreign energy, the MIURA STEAM BOILER has been engineered as a highly efficient, vertical water tube, once-through, forced-flow design. The MIURA Boiler features a compact unit with a low-water content and is designed to run with a minimum amount of maintenance with simple push-button controls. Operation is quiet, radiant heat losses are minimal, and steam quality is second to none. Miura Boilers are often installed in a multiple boiler network. MIURA Boilers, along with the patented MIURA Multiple Installation panel, allows appropriate horsepower to be brought on and off line quickly to meet sophisticated production needs with maximum fuel economy. The 40-year, field proven 'Miura Advantage' is the ability to reach full output steam from cold start in less than 5 minutes using the least amount of energy and having the lowest environmental impact. The high efficiency Miura Boiler has won numerous awards from Engineering Societies and Gas Associations because it is a compact, safe, cost-effective boiler.

## **1.4 FEATURES**

The MIURA STEAM BOILER is a once through, forced flow, low water content, water tube boiler design, which provides full output within 5 minutes. Miura Boiler is designed to run with a minimum amount of maintenance with simple, push-button controls. With the patented Miura XJ1 computer controller, Miura can monitor detailed boiler operation from our offices and provide fast, accurate data. Radiant heat losses are minimal and steam quality is second to none. Miura Boilers are often installed in a multiple boiler network. Miura Boilers, along with the patented Miura Multiple Installation panel, allows appropriate horsepower to be brought on and off line quickly to meet sophisticated production needs with maximum economy. This high efficiency Miura Boiler has won numerous awards in Japan, including awards from the Japanese Society of Mechanical Engineers and the Japanese Gas Association. In addition, it is a compact, safe, cost saving boiler. Those features are proven by the greater than 55% market share in the Pacific Rim.

Listed below are some of the standard features of the EX:

- Boiler design is UL, c-UL and/or CSA/CGA approved and labeled (IRI and/or FM available)
- High and Low Gas pressure switches
- Low Air pressure switch
- Main gas line & Pilot line regulators
- Dual pilot gas solenoid valves
- Dual main gas fluid actuator valves and plugged leak test port (vent valve available)
- Forced draft blower and motor
- Thermocouple on water tube to prevent over heat due to low water condition or scale build up
- Two independent Low-water fuel cutoffs, one with manual reset
- Two independent water volume controls
- Intermittent Automatic Blowdown system with strainer and manual shut off valve
- Control Steam Pressure transducer with backup control pressure switch.
- High Steam limit pressure switch with manual reset
- ASME safety relief valves for boiler & optional economizer

- Completely enclosed, heavy gauge casing
- ASME stamped Pressure Vessel with internal Inspection ports
- External steam separator
- Digital display steam pressure with back up pressure gauge
- MIURA XJ1 Microprocessor Boiler Control with friendly digital display
- Communication interface capability
- Display of hours of operation and record of five most recent faults
- Oil pump with motor and oil solenoid valves for oil fired boilers

## **1.5 DESCRIPTION**

The following answers frequently asked questions through a general overview of the design and operational characteristics of Miura Boilers.

The Miura boiler design consists of straight water tubes between upper and lower annular headers. Both headers are encased in a castable refractory leaving only the tubes exposed to combustion gases. There is very little water and consequently very little energy stored in the steam boiler. Water volume is exclusively in the tubes with only incidental bubbling in the upper header. Therefore, the design has no natural circulation such as a riser, down comer effect common to natural circulation boilers.

Water is forced into the bottom header and tubes by means of a feed water pump. The water is flashed into steam in the tubes, forming a dynamic bubbling system that cools the tubes. This bubbling action may be best described as a "steam gradient," with more steam at the top of the tubes than at the bottom. Steam is accumulated in the upper header with a final separation in the external separator. Condensate dropped by the external separator is fed back into the lower header.

Because of the steam gradient, there is no defined steam/water level and thus no sight glass. Special modifications are incorporated into the boiler construction and safety system to accommodate this.

First, probes are inserted directly into the top of the tubes. One probe is long, for low water cut out; and one probe is short for feed water control. This water volume control relies on electrical resistance and the bubbling action is what cools the tubes. As the volume of water in the steam boiler is consumed, there is less bubbling at the top of the tubes, increasing the amount of electrical resistance. Once the effective electrical resistance reaches a pre-determined level, a ten-second-time delay is tripped after which the feed water pump is turned on. It continues to run until the bubbles re-establish effective contact with the probe. Should the water volume ever become so low as to lose effective contact with the low water cutout probe, the boiler will shut down.

Secondly, probes are inserted into a water column on the side of the boiler. This water control system relies on a more conventional, electrical conductance system: when water contacts a probe, a circuit is formed. Three probes control the boiler feed with the short probe for high-fire, the medium length probe for low-fire and the long probe as low water cutout. This safety can be

confusing for the inspector who encounters the Miura steam generator in the field for the first time, because a water column typically equals a "fixed water level". This is not true, however, for the Miura steam boiler because of the low water content and the fierce boiling action of the steam gradient. This dynamic system is controlled only by a special modification of the water column to create an artificial level. The flanged pipe leading from the boiler body runs through the column with three holes drilled in the pipe to create an orifice effect. Yet even with this orifice effect, the artificial "level" oscillates - especially with load swings on the system. This oscillation is desired and is directly proportional to the volume of water in the boiler tubes.

Either of these feed water control systems can operate without the other for proper feed water control. However, the combination of these two systems provides for double low water safety and is called the "two-way water volume control system."

Thirdly, thermocouples are attached directly to the tubes. The thermocouples measure the temperature of the tube and will shut the boiler down if a low water volume condition is detected due to insufficient bubbling, dry fire or if scale build-up is detected. Scale formation is monitored directly by the rise in tube surface temperature because of lower heat transfer rates. This temperature sensing method can detect a formation of scale of less than  $\frac{1}{64}$ " and will shut down the boiler. The early detection of scale formation is an important factor in maintaining a high efficiency boiler. According to the US National Bureau of standards,  $\frac{1}{4}$ " of scale build up on heating units requires up to 55% more energy to attain the same temperature. Other methods of detecting scale, such as a pressure gauge on the discharge of the feed water pump, are much less sensitive.

The boiler will not operate should any of these low water safeties fail. Only through tampering could the boiler operate without these safeties and develop a dry fire condition. Even in the unlikely event this condition should ever be created, by the time the tubes superheat enough to destroy the tensile strength of the metal, the amount of energy contained in the remaining water is so small that the possibility of a pressure explosion is negligible.

The Miura Steam boiler design has been used for more than thirty-five years with over 200,000 units presently in operation worldwide. There is no record of ANY pressure vessel explosion.

Steam is produced within five minutes from cold start-up and selected tubes can be visually inspected through two-inch openings located on the top and bottom headers. A complete inspection is typically accomplished in a thirty-minute period.

All Miura steam boilers are annotated as a forced flow steam generator (with no fixed steam or water level) on the pressure vessel's P-3 form and registered with the National Board. The complete packaged steam boiler is listed with UL and CSA/CGA as a standard and can be built to IRI, FM and/or ASME-CSD1 at customer request.

Please note that all flanges used on all EX boilers are class 150# (EXH used class 300#) and comply with ASME/ANSI standard B16.5. The 150# stamping refers to a standard classification not Maximum Allowable Working Pressure (MAWP). As specified in Table A-361 of ASME codes, Section I, 2004 edition, the MAWP for 150# flanges is 205 PSIG for saturated steam

service and 170 PSIG for Boiler Feed and Blow-off line service. This specification matches the 170 PSI MAWP rating of the EX boiler.

**CAUTION: All steam systems require continuous proper water treatment. This treatment is mandatory from the time your MIURA BOILER is installed. Failure to follow the recommended water treatment and maintenance procedures could shorten the life (as well as the efficiency) of your boiler and could affect the warranty.**

**DANGER: Change from standard boiler to FGR boiler must be properly set up by a Miura representative.**

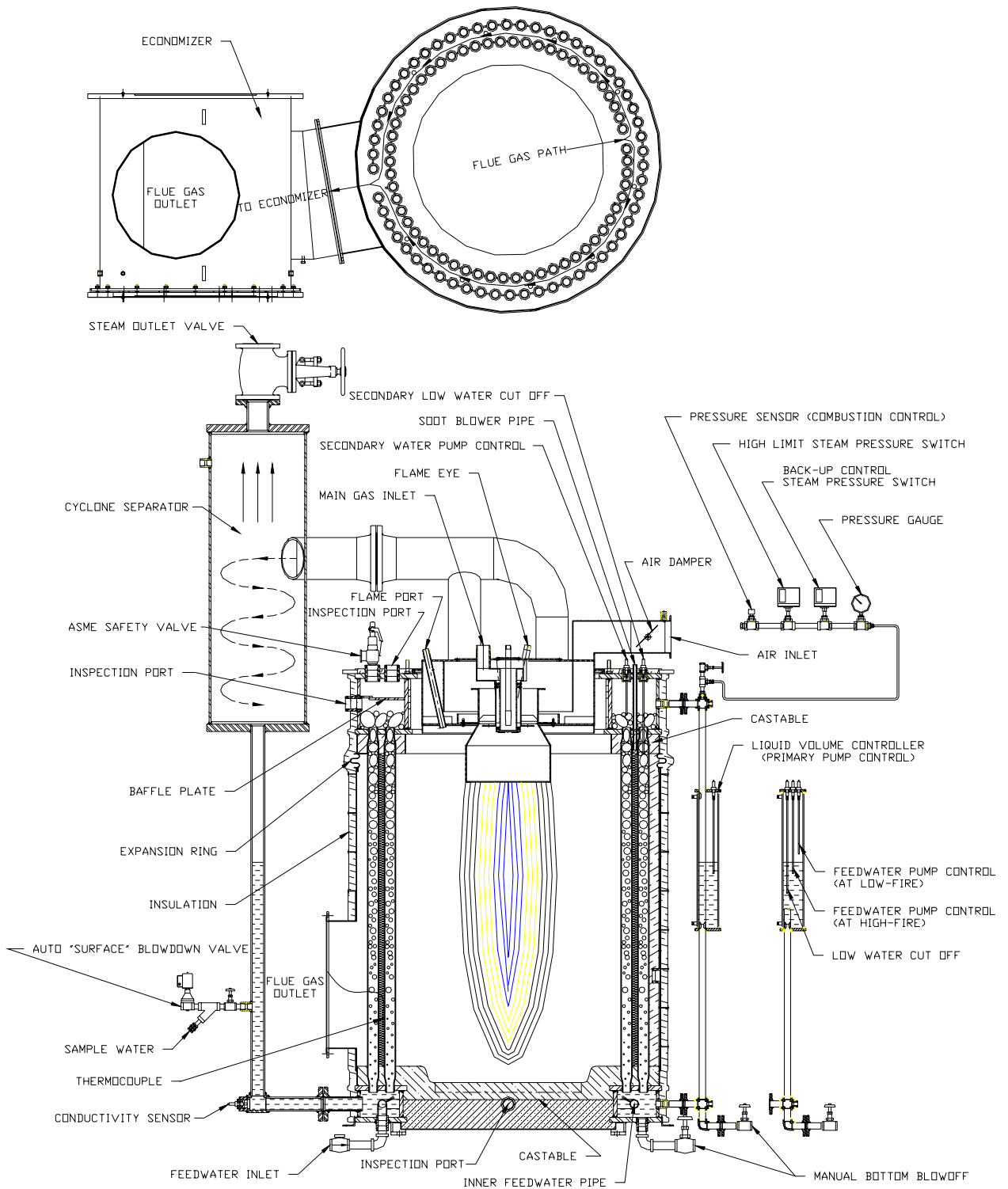

EX BOILER SECTION VIEW

Figure 1

## 1.6 SPECIFICATION

### 1.6.1 SPECIFICATION FOR EX-100

ITEM		UNITS	EX-100 G (O)	EX-100 SG (O F)
Boiler Type		Multiple water tube, once through, forced flow, steam boiler		
Boiler Horsepower Rating		BHP	100	
Maximum Working Pressure		PSIG (Kg/cm <sup>2</sup> )	170 (11.95)	
Equivalent Output		Lb./Hr (Kg/Hr)	3,450 (1,565)	
Heat Output		BTU/Hr (Kcal/Hr)	3,348,000 (843,600)	
Heat Input (Gas)			4,185,000 (1,054,000)	3,939,000 (992,400)
Efficiency (fuel to steam)		% (Gas/Oil)	80 / 82	85 / 87
Boiler Heating Surface Area		Ft <sup>2</sup> (m <sup>2</sup> )	193 (17.9)	
Operational Weight		Lb. (Kg)	5,500 (2,500)	7,250 (3,300)
Shipping Weight		Lb. (Kg)	5,000 (2,250)	6,750 (3,050)
Combustion Control		HI-LOW-OFF, 3 position step burner		
Combustion System		Forced draft burner		
Ignition System		Electric spark ignited, interrupted gas pilot		
Power Supply		575, 460, or 230 V, 3 phase, 60 Hz		
Max. Electrical Consumption	Without	KVA (Gas/Oil)	13.4 / 13.9	
	With FGR		N/A	21.2 / 23.1
Natural Gas/No. 2 Oil Consumption		SCFH / Gal	4,170 / 29.2	3,920 / 27.5
Fuel Supply Pressure		PSIG	3 - 5 (Natural Gas or Propane)	
Flue Gas Volume (Wet)		SCFH (Nm <sup>3</sup> /Hr)	55,900 (1,494)	52,500 (1,406)
Flue Gas Volume (Dry)			47,700 (1,273)	44,900 (1,199)
Flue Gas Velocity		Ft/s (m/s)	26 (7.9)	19.1 (5.8)
Main Steam Outlet		Inches	2"	
Safety Valve Outlet			1½" for boiler and optional 1¼" for economizer	
Main Water Inlet			1"	
Fuel Gas Inlet			2"	
Fuel Oil Inlet			¾"	
Automatic "Surface" Blowdown			⅜"	
Boiler & LVC Drain			2 x 1"	
Chimney Diameter			14"	
Flame Detector			Ultraviolet flame eye sensor	
Overheating Protection		Low water cutoff & thermocouple		

**NOTE:**

- i) Equivalent Output is calculated from and at 212°F (100°C) feedwater to 212°F (100°C) steam.
- ii) Gas consumption is based on Natural Gas with High heating value of 1,004 Btu/SCF.
- iii) Thermal Efficiencies are based on high heating values of fuels.
- iv) Flue gas velocity & efficiency are calculated for Natural Gas with 68°F (20°C) feedwater.
- v) Boiler Safety valve Outlet size may increase if set below 170 PSIG.

### 1.6.2 SPECIFICATION FOR EX-200

ITEM		UNITS	EX-200 G (O)	EX-200 SG (O F)
Boiler Type		Multiple water tube, once through, forced flow, steam boiler		
Boiler Horsepower Rating		BHP	200	
Maximum Working Pressure		PSIG (Kg/cm <sup>2</sup> )	170 (11.95)	
Equivalent Output		Lb./Hr (Kg/Hr)	6,900 (3,129)	
Heat Output		BTU/Hr (Kcal/Hr)	6,695,000 (1,687,000)	
Heat Input			8,369,000 (2,109,000)	7,876,000 (1,985,000)
Efficiency (fuel to steam)		% (Gas/Oil)	80 / 82	85 / 87
Boiler Heating Surface Area		Ft <sup>2</sup> (m <sup>2</sup> )	323 (30.0)	
Operational Weight		Lb. (Kg)	9,700 (4,400)	11,500 (5,200)
Shipping Weight		Lb. (Kg)	9,000 (4,080)	10,650 (4,850)
Combustion Control		HI-LOW-OFF, 3 position step burner		
Combustion System		Forced draft burner		
Ignition System		Electric spark ignited, interrupted gas pilot		
Power Supply		575, 460, or 230 V, 3 phase, 60 Hz		
Max. Electrical Consumption	Without FGR	KVA (Gas/Oil)	24 / 25	
	With FGR		N/A	28.2 / 29.2
Natural Gas/No. 2 Oil Consumption		SCFH / Gal	8,340 / 58.3	7,850 / 55.0
Fuel Supply Pressure		PSIG	3 - 5 (Natural Gas or Propane)	
Flue Gas Volume (Wet)		SCFH (Nm <sup>3</sup> /Hr)	112,000 (2,987)	105,200 (2,812)
Flue Gas Volume (Dry)			95,500 (2,547)	89,900 (2,397)
Flue Gas Velocity		Ft/s (m/s)	25.4 (7.7)	18.8 (5.7)
Main Steam Outlet		Inches	3"	
Safety Valve Outlet			2½" for boiler and optional 1¼" for economizer	
Main Water Inlet			1"	
Fuel Gas Inlet			2"	
Fuel Oil Inlet			¾"	
Automatic "Surface" Blowdown			⅜"	
Boiler & LVC Drain			2 x 1"	
Chimney Diameter			20"	
Flame Detector			Ultraviolet flame eye sensor	
Overheating Protection		Low water cutoff & thermocouple		

**NOTE:**

- i) Equivalent Output is calculated from and at 212°F (100°C) feedwater to 212°F (100°C) steam.
- ii) Gas consumption is based on Natural Gas with High heating value of 1,004 Btu/SCF.
- iii) Thermal Efficiencies are based on high heating values of fuels.
- iv) Flue gas velocity & efficiency are calculated for Natural Gas with 68°F (20°C) feedwater.
- v) Boiler Safety valve Outlet size may increase if set below 170 PSIG.

### 1.6.3 SPECIFICATION FOR EX-250

ITEM		UNITS	EX-250 G (O)	EX-250 SG (O F)
Boiler Type		Multiple water tube, once through, forced flow, steam boiler		
Boiler Horsepower Rating		BHP	250	
Maximum Working Pressure		PSIG (Kg/cm <sup>2</sup> )	170 (11.95)	
Equivalent Output		Lb./Hr (Kg/Hr)	8,625 (3,912)	
Heat Output		BTU/Hr (Kcal/Hr)	8,369,000 (2,109,000)	
Heat Input			10,461,000 (2,636,000)	9,846,000 (2,481,000)
Efficiency (fuel to steam)		% (Gas/Oil)	80 / 82	85 / 87
Boiler Heating Surface Area		Ft <sup>2</sup> (m <sup>2</sup> )	407 (37.8)	
Operational Weight		Lb. (Kg)	15,000 (6,800)	17,850 (8,100)
Operational Weight		Lb. (Kg)	13,800 (6,300)	16,600 (7,500)
Combustion Control		HI-LOW-OFF, 3 position step burner		
Combustion System		Forced draft burner		
Ignition System		Electric spark ignited, interrupted gas pilot		
Power Supply		575, 460, or 230 V, 3 phase, 60 Hz		
Max. Electrical Consumption	Without	KVA (Gas/Oil)	30.4 / 31.6	
	With FGR		N/A	30.4 / 31.6
Natural Gas/No. 2 Oil Consumption		SCFH / Gal	10,420 / 72.9	9,810 / 68.7
Fuel Supply Pressure		PSIG	3 - 5 (Natural Gas or Propane)	
Flue Gas Volume (Wet)		SCFH (Nm <sup>3</sup> /Hr)	139,600 (3,734)	131,400 (3,514)
Flue Gas Volume (Dry)			119,300 (3,184)	112,300 (2,996)
Flue Gas Velocity with/without FGR		Ft/s (m/s)	19.5 (5.9) / 32.9 (10.0)	13.9 (4.2) / 23.5 (7.2)
Main Steam Outlet		Inches	4"	
Safety Valve Outlet			2 x 2½" for boiler and optional 1¼" for economizer	
Main Water Inlet			1¼"	
Fuel Gas Inlet			2½"	
Fuel Oil Inlet			¾"	
Automatic "Surface" Blowdown			2 x ¾"	
Boiler & LVC Drain			2 x 1"	
Chimney Diameter with/without FGR			26" / 20"	
Flame Detector			Ultraviolet flame eye sensor	
Overheating Protection		Low water cutoff & thermocouple		

**NOTE:**

- i) Equivalent Output is calculated from and at 212°F (100°C) feedwater to 212°F (100°C) steam.
- ii) Gas consumption is based on Natural Gas with High heating value of 1,004 Btu/SCF.
- iii) Thermal Efficiencies are based on high heating values of fuels.
- iv) Flue gas velocity & efficiency are calculated for Natural Gas with 68°F (20°C) feedwater.
- v) Boiler Safety valve Outlet size may increase if set below 170 PSIG.

### 1.6.4 SPECIFICATION FOR EX-300

ITEM		UNITS	EX-300 G (O)	EX-300 SG (O F)
Boiler Type		Multiple water tube, once through, forced flow, steam boiler		
Boiler Horsepower Rating		BHP	300	
Maximum Working Pressure		PSIG (Kg/cm <sup>2</sup> )	170 (11.95)	
Equivalent Output		Lb./Hr (Kg /Hr)	10,350 (4,694)	
Heat Output		BTU/Hr (Kcal/Hr)	10,050,000 (2,531,000)	
Heat Input			12,563,000 (3,166,000)	11,824,000 (2,977,000)
Efficiency (fuel to steam)		% (Gas/Oil)	80 /82	85 / 87
Boiler Heating Surface Area		Ft <sup>2</sup> (m <sup>2</sup> )	390 (36.2)	
Operational Weight		Lb. (Kg)	15,000 (6,800)	18,000 (8,200)
Shipping Weight		Lb. (Kg)	13,800 (6,300)	17,100 (7,800)
Combustion Control		HI-LOW-OFF, 3 position step burner		
Combustion System		Forced draft burner		
Ignition System		Electric spark ignited, interrupted gas pilot		
Power Supply		575, 460, or 230 V, 3 phase, 60 Hz		
Max. Electrical Consumption	Without	KVA (Gas/Oil)	30.4 / 31.6	
	With FGR		N/A	43.9 / 45.7
Natural Gas/No. 2 Oil Consumption		SCFH / Gal	12,500 / 87.5	11,780 / 82.5
Fuel Supply Pressure		PSIG	3 - 5 (Natural Gas or Propane)	
Flue Gas Volume (Wet)		SCFH (Nm <sup>3</sup> /Hr)	167,500 (4,481)	157,800 (4,217)
Flue Gas Volume (Dry)			143,000 (3,820)	134,800 (3,596)
Flue Gas Velocity		Ft/s (m/s)	22.6 (6.9)	16.7 (5.1)
Main Steam Outlet		Inches	4"	
Safety Valve Outlet			2 x 2½" for boiler and optional 1¼" for economizer	
Main Water Inlet			1¼"	
Fuel Gas Inlet			2½"	
Fuel Oil Inlet			¾"	
Automatic "Surface" Blowdown			2 x ¾"	
Boiler & LVC Drain			1¼"+ 1"	
Chimney Diameter			26"	
Flame Detector			Ultraviolet flame eye sensor	
Overheating Protection		Low water cutoff & thermocouple		

**NOTE:**

- i) Equivalent Output is calculated from and at 212°F (100°C) feedwater to 212°F (100°C) steam.
- ii) Gas consumption is based on Natural Gas with High heating value of 1,004 Btu/SCF.
- iii) Thermal Efficiencies are based on high heating values of fuels.
- iv) Flue gas velocity & efficiency are calculated for Natural Gas with 68°F (20°C) feedwater.
- v) Boiler Safety valve Outlet size may increase if set below 170 PSIG.

### 1.6.5 SPECIFICATION FOR EXN-300

ITEM	UNITS	EXN-300 SG (O) F
Boiler Type	Multiple water tube, once through, forced flow, steam boiler	
Boiler Horsepower Rating	BHP	300
Maximum Working Pressure	PSIG (Kg/cm <sup>2</sup> )	170 (11.95)
Equivalent Output	Lb./Hr (Kg /Hr)	10,350 (4,694)
Heat Output	BTU/Hr (Kcal/Hr)	10,050,000 (2,531,000)
Heat Input		11,824,000 (2,977,000)
Efficiency (fuel to steam)	% (Gas/Oil)	85 / 87
Boiler Heating Surface Area	Ft <sup>2</sup> (m <sup>2</sup> )	468 (43.4)
Operational Weight	Lb. (Kg)	19,500 (8,900)
Shipping Weight	Lb. (Kg)	17,300 (7,900)
Combustion Control	HI-LOW-OFF, 3 position step burner	
Combustion System	Forced draft burner	
Ignition System	Electric spark ignited, interrupted gas pilot	
Power Supply	575, 460, or 230 V, 3 phase, 60 Hz	
Max. Electrical Consumption	KVA (Gas/Oil)	30.4 / 32.0
Natural Gas/No. 2 Oil Consumption	SCFH / Gal	11,780 / 82.5
Fuel Supply Pressure	PSIG	3 - 5 (Natural Gas)
Flue Gas Volume (Wet)	SCFH (Nm <sup>3</sup> /Hr)	157,800 (4,217)
Flue Gas Volume (Dry)		134,800 (3,596)
Flue Gas Velocity	Ft/s (m/s)	16.7 (5.1)
Main Steam Outlet	Inches	4"
Safety Valve Outlet		2 x 2½" for boiler and optional 1¼" for economizer
Main Water Inlet		1¼"
Fuel Gas Inlet		2½"
Fuel Oil Inlet		¾"
Automatic "Surface" Blowdown		2 x ¾"
Boiler & LVC Drain		1¼"+ 1"
Chimney Diameter		26"
Flame Detector		Ultraviolet flame eye sensor
Overheating Protection	Low water cutoff & thermocouple	

**NOTE:**

- i) Equivalent Output is calculated from and at 212°F (100°C) feedwater to 212°F (100°C) steam.
- ii) Gas consumption is based on Natural Gas with High heating value of 1,004 Btu/SCF.
- iii) Thermal Efficiencies are based on high heating values of fuels.
- iv) Flue gas velocity & efficiency are calculated for Natural Gas with 68°F (20°C) feedwater.
- v) Boiler Safety valve Outlet size may increase if set below 170 PSIG.

### 1.6.6 SPECIFICATION FOR EXH-100

ITEM	UNITS	EXH-100 G (O)	EXH-100 SG (O)
Boiler Type	Multiple water tube, once through, forced flow, steam boiler		
Boiler Horsepower Rating	BHP	100	
Maximum Working Pressure	PSIG (Kg/cm <sup>2</sup> )	250 (17.6)	
Equivalent Output	Lb./Hr (Kg/Hr)	3,450 (1,565)	
Heat Output	BTU/Hr (Kcal/Hr)	3,348,000 (843,600)	
Heat Input		4,185,000 (1,054,000)	3,939,000 (992,400)
Efficiency (fuel to steam)	% (Gas/Oil)	80 / 82	85 / 87
Boiler Heating Surface Area	Ft <sup>2</sup> (m <sup>2</sup> )	193 (17.9)	
Operational Weight	Lb. (Kg)	5,600 (2,540)	7,400 (3,400)
Shipping Weight	Lb. (Kg)	5,100 (2,300)	6,900 (3,150)
Combustion Control	HI-LOW-OFF, 3 position step burner		
Combustion System	Forced draft burner		
Ignition System	Electric spark ignited, interrupted gas pilot		
Power Supply	575, 460, or 230 V, 3 phase, 60 Hz		
Max. Electrical Consumption	KVA (Gas/Oil)	14.8 / 16.2	
Natural Gas/No. 2 Oil Consumption	SCFH / Gal	4,170 / 29.2	3,920 / 27.5
Fuel Supply Pressure	PSIG	3 - 5 (Natural Gas or Propane)	
Flue Gas Volume (Wet)	SCFH (Nm <sup>3</sup> /Hr)	55,900 (1,494)	52,500 (1,406)
Flue Gas Volume (Dry)		47,700 (1,273)	44,900 (1,199)
Flue Gas Velocity	Ft/s (m/s)	27.5 (8.4)	20.2 (6.2)
Main Steam Outlet	Inches	2"	
Safety Valve Outlet		1½" for boiler and optional 1¼" for economizer	
Main Water Inlet		1"	
Fuel Gas Inlet		2"	
Fuel Oil Inlet		¾"	
Automatic "Surface" Blowdown		¾"	
Boiler & LVC Drain		2 x 1"	
Chimney Diameter		14"	
Flame Detector		Ultraviolet flame eye sensor	
Overheating Protection	Low water cutoff & thermocouple		

**NOTE:**

- i) Equivalent Output is calculated from and at 212°F (100°C) feedwater to 212°F (100°C) steam.
- ii) Gas consumption is based on Natural Gas with High heating value of 1,004 Btu/SCF.
- iii) Thermal Efficiencies are based on high heating values of fuels.
- iv) Flue gas velocity & efficiency are calculated for Natural Gas with 68°F (20°C) feedwater.

v) Boiler Safety valve Outlet size may increase if set below 250 PSIG.

1.6.7 SPECIFICATION FOR EXH-200

ITEM	UNITS	EXH-200 G (O)	EXH-200 SG (O)	
Boiler Type	Multiple water tube, once through, forced flow, steam boiler			
Boiler Horsepower Rating	BHP	200		
Maximum Working Pressure	PSIG (Kg/cm <sup>2</sup> )	250 (17.6)		
Equivalent Output	Lb./Hr (Kg /Hr)	6,900 (3,129)		
Heat Output	BTU/Hr (Kcal/Hr)	6,695,000 (1,687,000)		
Heat Input		8,369,000 (2,109,000)	7,876,000 (1,985,000)	
Efficiency (fuel to steam)	% (Gas/Oil)	80 / 82	85 / 87	
Boiler Heating Surface Area	Ft <sup>2</sup> (m <sup>2</sup> )	323 (30.0)		
Operational Weight	Lb. (Kg)	10,000 (4,500)	11,800 (5,350)	
Shipping Weight	Lb. (Kg)	9,300 (4,200)	10,950 (5,000)	
Combustion Control	HI-LOW-OFF, 3 position step burner			
Combustion System	Forced draft burner			
Ignition System	Electric spark ignited, interrupted gas pilot			
Power Supply	575, 460, or 230 V, 3 phase, 60 Hz			
Max. Electrical Consumption	KVA (Gas/Oil)	28.8 / 29.7		
Natural Gas/No. 2 Oil Consumption	SCFH / Gal	8,340 / 58.3	7,850 / 55.0	
Fuel Supply Pressure	PSIG	3 - 5 (Natural Gas or Propane)		
Flue Gas Volume (Wet)	SCFH (Nm <sup>3</sup> /Hr)	111,700 (2,987)	105,200 (2,812)	
Flue Gas Volume (Dry)		95,500 (2,547)	89,900 (2,397)	
Flue Gas Velocity	Ft/s (m/s)	26.9 (8.2)	19.9 (6.1)	
Main Steam Outlet	Inches	3"		
Safety Valve Outlet		2½" for boiler and optional 1¼" for economizer		
Main Water Inlet		1"		
Fuel Gas Inlet		2"		
Fuel Oil Inlet		¾"		
Automatic "Surface" Blowdown		⅜"		
Boiler & LVC Drain		2 x 1"		
Chimney Diameter		20"		
Flame Detector		Ultraviolet flame eye sensor		
Overheating Protection		Low water cutoff & thermocouple		

NOTE:

- i) Equivalent Output is calculated from and at 212°F (100°C) feedwater to 212°F (100°C) steam.
- ii) Gas consumption is based on Natural Gas with High heating value of 1,004 Btu/SCF.
- iii) Thermal Efficiencies are based on high heating values of fuels.
- iv) Flue gas velocity & efficiency are calculated for Natural Gas with 68°F (20°C) feedwater.
- v) Boiler Safety valve Outlet size may increase if set below 250 PSIG.

### 1.6.8 SPECIFICATION FOR EXH-300

ITEM	UNITS	EXH-300 G (O)	EXH-300 SG (O)	
Boiler Type	Multiple water tube, once through, forced flow, steam boiler			
Boiler Horsepower Rating	BHP	300		
Maximum Working Pressure	PSIG (Kg/cm <sup>2</sup> )	250 (17.6)		
Equivalent Output	Lb./Hr (Kg /Hr)	10,350 (4,694)		
Heat Output	BTU/Hr (Kcal/Hr)	10,050,000 (2,531,000)		
Heat Input		12,722,000 (3,206,000)	11,964,000 (3,015,000)	
Efficiency (fuel to steam)	% (Gas/Oil)	79 / 81	84 / 86	
Boiler Heating Surface Area	Ft <sup>2</sup> (m <sup>2</sup> )	390 (36.2)		
Operational Weight	Lb. (Kg)	15,300 (6,900)	18,300 (8,300)	
Shipping Weight	Lb. (Kg)	14,100 (6,400)	17,400 (7,900)	
Combustion Control	HI-LOW-OFF, 3 position step burner			
Combustion System	Forced draft burner			
Ignition System	Electric spark ignited, interrupted gas pilot			
Power Supply	575, 460, or 230 V, 3 phase, 60 Hz			
Max. Electrical Consumption	KVA (Gas/Oil)	36.7 / 38.6		
Natural Gas/No. 2 Oil Consumption	SCFH / Gal	12,670 / 88.6	11,920 / 83.5	
Fuel Supply Pressure	PSIG	3 - 5 (Natural Gas or Propane)		
Flue Gas Volume (Wet)	SCFH (Nm <sup>3</sup> /Hr)	169,700 (4,481)	159,700 (4,217)	
Flue Gas Volume (Dry)		145,000 (3,820)	136,400 (3,596)	
Flue Gas Velocity	Ft/s (m/s)	23.6 (7.2)	17.6 (5.4)	
Main Steam Outlet	Inches	4"		
Safety Valve Outlet		2½" for boiler and optional 1¼" for economizer		
Main Water Inlet		1¼"		
Fuel Gas Inlet		2½"		
Fuel Oil Inlet		¾"		
Automatic "Surface" Blowdown		⅜"		
Boiler & LVC Drain		2 x 1"		
Chimney Diameter		26"		
Flame Detector		Ultraviolet flame eye sensor		
Overheating Protection		Low water cutoff & thermocouple		

**NOTE:**

- i) Equivalent Output is calculated from and at 212°F (100°C) feedwater to 212°F (100°C) steam.
- ii) Gas consumption is based on Natural Gas with High heating value of 1,004 Btu/SCF.
- iii) Thermal Efficiencies are based on high heating values of fuels.
- iv) Flue gas velocity & efficiency are calculated for Natural Gas with 68°F (20°C) feedwater.
- v) Boiler Safety valve Outlet size may increase if set below 250 PSIG.

## SECTION 2 ACTS & REGULATIONS

### 2.1 ACTS & REGULATIONS

There are a number of codes, standards, laws and regulations for boilers and related equipment that and should be considered. Regulatory requirements are dictated by a variety of sources and are focused primarily on safety. The equipment shall be installed in accordance with the current regulations, codes and specifications of the applicable City, Country, Provincial/State and Federal agencies. Authorities having jurisdiction should be consulted before installations are made. For more information on how the various rules affect boiler selection and operation, you may want to contact your local MIURA authorized representative or the engineering firm designing the boiler installation. Here are some essential rules to consider:

- a) The boiler industry is tightly regulated by the American Society of Mechanical Engineers (ASME) and ASME Codes, which controls boiler design, inspection, and quality assurance. All boilers' pressure vessels including economizers, deaerator, blowdown tank and other pressure vessels should have an ASME stamp.
- b) All pressure vessels should be inspected and registered with the National Board.
- c) In Canada, the design of all boilers, pressure vessels, fittings, and piping must be registered with local province as required in CSA B51.
- d) The insurance company insuring the facility or boiler may dictate additional requirements. Boiler manufacturers can provide special boiler trim according to the requirements of major insurance companies such as IRI, FM. Special boiler trim items usually pertain to added safety controls. Some industries, such as food processing, brewing, or pharmaceuticals may also have additional regulations that have an impact on the boiler and boiler room.
- e) CSA/CGA, c-UL, UL approval may be required to verify boiler safety performance.
- f) A full time boiler operator may be required. Operator requirements depend on the boiler's size, pressure, heating surface area and volume of water. Boilers can be selected to minimize the boiler operator requirements; either by choosing a boiler that is exempt from the rules, or by installing special equipment that gives the operator more freedom in the facility. Contact the local boiler inspector for details.
- g) Most state/province or local authorities require a permit to install and operate a boiler. Additional restrictions may apply in non-attainment areas where air quality does not meet the national ambient air quality standards and emission regulations are more stringent. Be sure to investigate these requirements before buying a boiler.
- h) Most states or provinces require an annual boiler inspection. There may be other requirements on piping as well.
- i) Most areas have established a maximum temperature at which water can be discharged to the sewer. In this case, a blowdown separator or blowdown tank is required.
- j) For all new boilers with inputs over 10 million Btu/Hr, U.S. Federal emission standards apply including permitting and reporting procedures.
- k) Ratings of boilers are based on sea level operation. For operation at elevations above 2,000 feet (600m), equipment ratings shall be reduced at the rate of 4 percent for each 1,000 feet (300m) above sea level.

## **2.2 NATIONAL REGULATORY ORGANIZATIONS**

MIURA Boiler recommends contacting your actual insurance provider as well as the utility companies for assistance in identifying and complying with codes and regulations.

A partial list of agencies having jurisdiction over boiler installation and operation is given below. This list is comprehensive but by no means all-inclusive.

### **UNDERWRITERS LABORATORIES**

333 Pfingsten Rd.  
Northbrook, IL  
60062  
(847) 272-8800

### **CSA INTERNATIONAL**

178 Rexdale Blvd.  
Etobicoke, Ontario  
M9W 1R3  
(416) 747-2300

### **NATIONAL BOARD**

1055 Crupper Ave.  
Columbus, OH  
43229  
(614) 888-8320

### **T.S.S.A.**

3300 Bloor St., West  
4<sup>th</sup> Floor, West Tower  
Etobicoke, Ontario M8X 2X4  
(416) 325-2000

### **A.S.M.E.**

345 East 47th St.  
New York, NY  
10017  
(212) 705-7800

### **N.F.P.A.**

1 Batterymarch Park  
P.O. Box 9101  
Quincy, MA 02269-9101  
(800) 344-3555

### **INDUSTRIAL RISK INSURERS**

85 Woodland Street,  
Hartford, CT 06105-1226

### **FACTORY MUTUAL RESEARCH CORPORATION**

1151 Boston-Providence Turnpike,  
Norwood, MA 02062  
(617) 762-4300

### **AMERICAN GAS ASSOCIATION**

1515 Wilson Boulevard  
Arlington, VA 22209

### **AMERICAN NATIONAL STANDARD INSTITUTE**

11 West 42<sup>nd</sup> Street,  
New York, NY 10036

### **OCCUPATIONAL SAFETY & HEALTH ADM.**

### **ENVIRONMENT PROTECTION AGENCY**

### **LOCAL FIRE MARSHALL**

### **LOCAL BUILDING & CONSTRUCTION INSP.**

### **LOCAL BOILER INSPECTION**

### **FOOD & DRUG ADMINISTRATION**

## SECTION 3 INSTALLATION

**CAUTION:** All boiler prices are F.O.B. the factory at Brantford, Ontario. This means that MIURA Boiler is not responsible for damage to the boiler occurring during shipping. We strongly recommend a complete inspection of all boiler shipments at place and time of delivery. This inspection should include photographs of the boiler and ancillary equipment packing crates. If any damage is found, do not release the driver or unload the equipment until a satisfactory arrangement is made with shipping company to cover the damage. MIURA Boiler makes reasonable effort to ensure that no vibration or shock damage will occur. However, if such damage occurs and is not discovered and noted at the time of delivery, MIURA Boiler is not responsible to pay for the cost of repairs and any damaged parts will not be under warranty.

**NOTE:** It is customer's responsibility to confirm utility availability before ordering the boiler and follow all local regulations.

### 3.1 UNLOADING

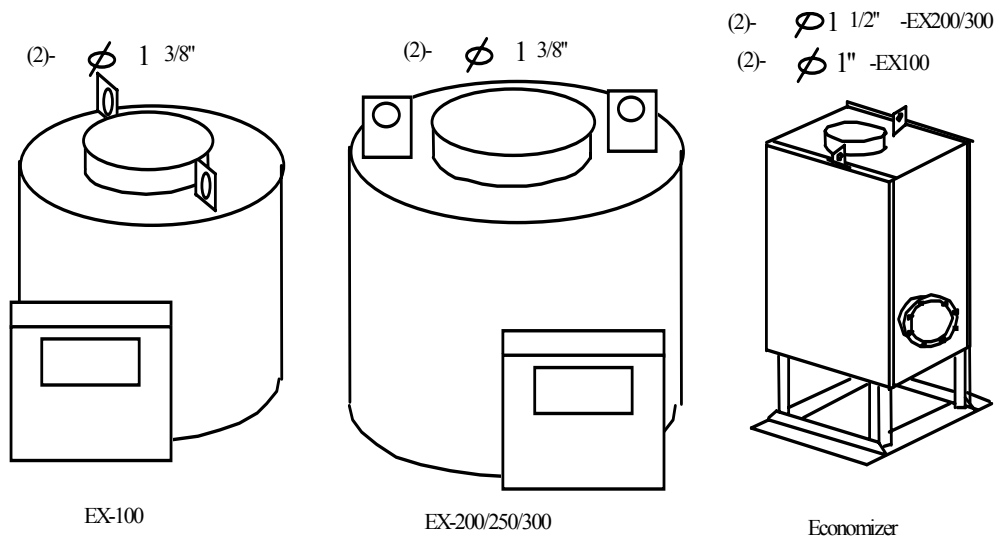

For transportation, the EX boiler may be disassembled and shipped in separate components as follows:

- Boiler vessel with burner and control box
- Blower assembly
- Optional Economizer (for S series)
- Ladder and Steam separator (for EX-250 & EX-300)
- Optional parts such as feed water pump, silencer, filter box, steam valve etc...

**NOTE:** Some small parts, such as bolts and nuts for economizer to boiler flange or steam separator, electrode etc. will be shipped inside associated control box for the boiler.

The EX series boiler may be unloaded from the transport truck using a forklift. However, if a forklift is used, precautions should be taken to ensure that the boiler does not tip over. The boiler's weight is not centered. Because of the many variables involved such as model, size of forklift and size of the loading dock, MIURA is not able to recommend a specific method of unloading the boiler. Securing the top of the boiler to the forklift with a chain or similar methods is strongly recommended.

### 3.2 ASSEMBLING

**CAUTION:** This is a completely shop tested, assembled and fully packaged boiler. Each unit and assembly has been well adjusted in the factory. It is very important not to make any adjustments without first consulting your nearest authorized MIURA dealer. Field reassembly is customer's responsibility.

#### 3.2.1 BLOWER ASSEMBLY

Place the blower on the foundation so that the blower outlet is directly under the windbox inlet. Tighten the foundation bolts. Install air hose between blower outlet and windbox inlet as straight as possible to reduce the pressure drop in this duct. Ensure that the hose is placed as far as possible over the air duct to minimize leakage, the chance that it will blow off, as well as eliminate any bend in the hose (trim any excess length if required). Tighten hose clamps.

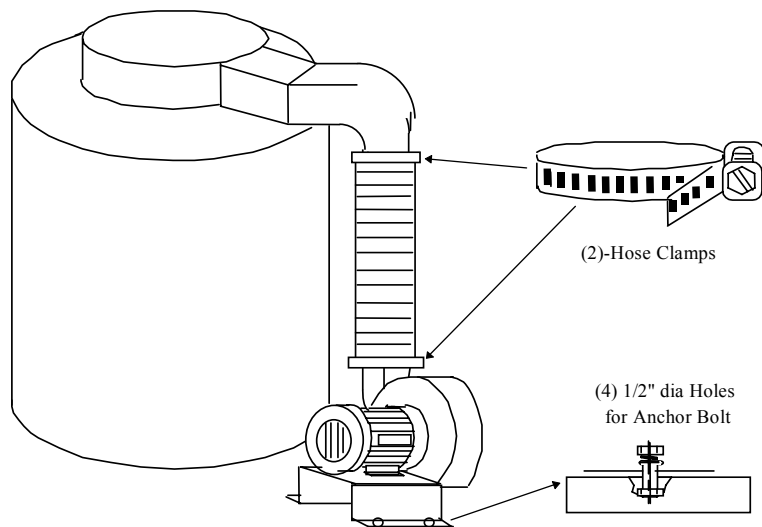

#### 3.2.2 STEAM SEPARATOR ASSEMBLY

The steam separator may be removed for shipping. The necessary bolts, nuts and gaskets are packaged inside the main control box.

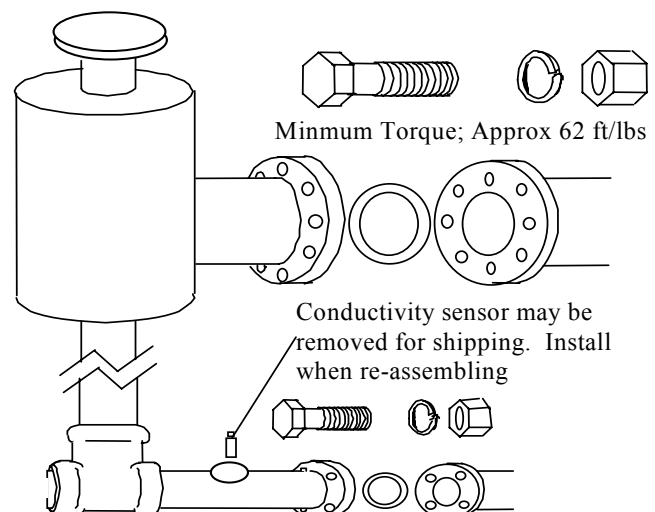

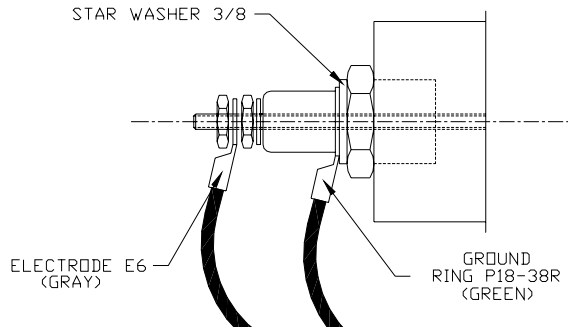

The electrode (conductivity sensor) may also be removed for shipping and packaged separately in the main control box. Please install the sensor in the location of the plastic cap at the bottom of the separator and connect wires provided as shown.

### 3.2.3 ECONOMIZER INSTALLATION (FOR EX-S MODEL ONLY)

Adjust the economizer height as necessary to match the economizer inlet flange with boiler outlet flange by using four adjusting bolts mounted on economizer base plate. Make sure the supplied gasket is still properly glued on the boiler's chimney outlet flange. Use supplied bolts and nuts that were packed in the control box to secure these flanges together. After the boiler to economizer joint has been sealed tight, place shims under economizer base. Then bolt the economizer to the foundation slab.

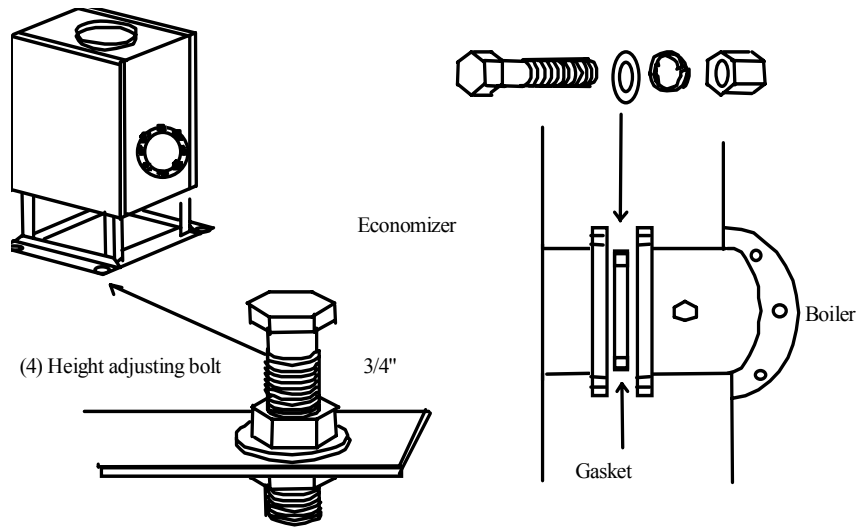

### 3.2.4 OPTIONAL FEED WATER PUMP

Feed water pump should be located under or close to the feed water tank. The suction pipe should be adequately sized and configured to minimize friction losses or air entrapment. **MIURA recommends at least six feet of water above the suction of the pump to prevent cavitation.**

The pump contactor and circuit protection provided in the control box are to be used only with feedwater pump recommended by MIURA at rated voltage and HP stamping on boiler nameplate. If different pump is used, please use external power supply and pump contact with proper protection.

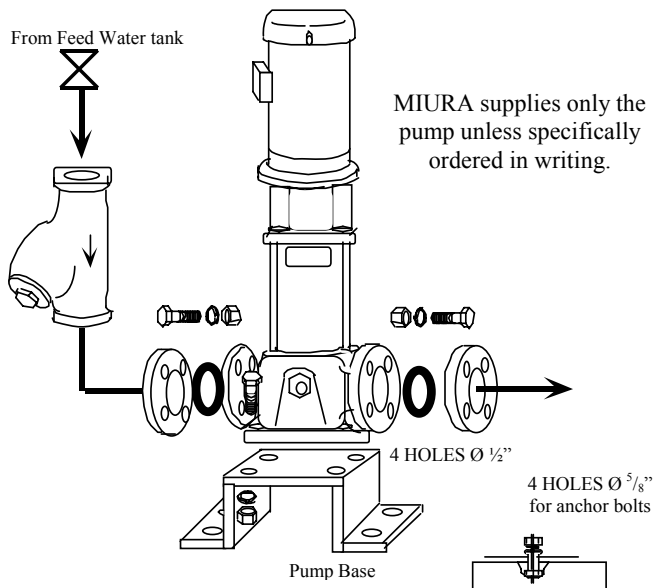

**NOTE: Prior to installing pump, softener and other equipment, review applicable instruction books.**

### 3.2.5 FOUNDATION & ANCHORING

The recommended foundation is a 6” concrete slab. Reinforcement of slab is not necessary if floor is solid. After positioning, anchor the boiler, blower, economizer ... to the foundation using 5/8” anchor bolts (not supplied by MIURA).

**NOTE: Installer and operator must identify emergency shut-off device, which includes power switch, main fuel (gas and/or oil), and water cock.**

## 3.3 STEAM & WATER PIPING

	EX-100	EX-200	EX-250	EX(N)-300	EXH-100	EXH-200	EXH-300
Water Inlet	1" NPT		1¼" NPT		1" NPT		1¼" NPT
Steam Outlet	2" NPT	3" FL 150#	4" FL 150#		2" NPT	3" FL 300#	4" FL 300#
Boiler Safety Valve Outlets	1½" NPT	2½" NPT	2 x 2½" NPT		1½" NPT	2½" NPT	2 x 2½" NPT
Economizer Safety Valve Outlet	1¼" NPT (if required)						

- Before boiler is fired for the first time after installation is completed, flush all piping. MIURA is not responsible for damage as a result of debris in piping such as stuck open check valve.
- Do not operate boiler for extended periods of time with feedwater temperature below 130°F.
- For installations where a Deaerator tank is installed, if expected condensate return is expected to exceed 50% of boiler capacity, a separate condensate surge tank is recommended.
- Please Contact your nearest MIURA representative or Distributor about accessories.
- Follow all local regulations.

### 3.3.1 STEAM PIPING

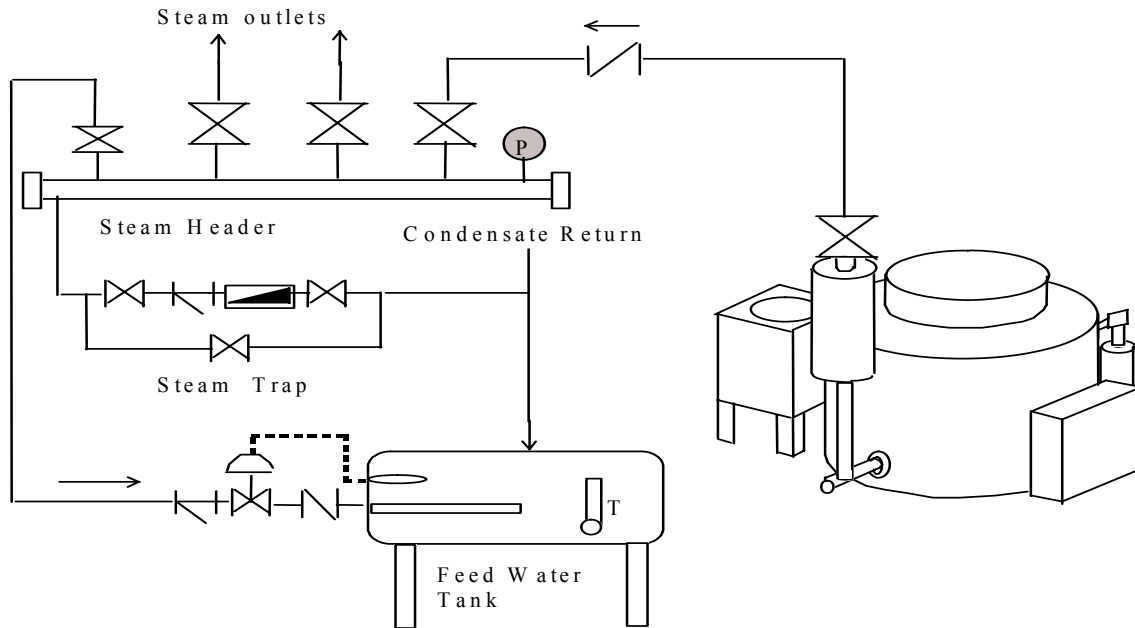

- MIURA Boiler recommends a check valve between the boiler outlet valve and the header isolation valve. Install the main steam check valve horizontally to prevent condensate build up above the check valve.
- Even though MIURA Boiler provides very dry steam, proper insulation and drainage of condensate from steam lines is still required in order to obtain dry steam at the point of use. Install the horizontal piping with sufficient slope and condensate drainage to prevent water accumulation in process steam supply piping. Recommended slope is 1" for every 200" to 300" horizontal run, sloping away from the boiler. For piping runs of more than 50 feet, consideration should be given to expansion joints in the steam piping to minimize piping stress on boiler and process equipment as a result of thermal expansion of the steam piping.
- Install a steam condensate drain trap on the main steam header to remove condensate prior to distribution to process steam lines. All low points in the steam piping should also have a condensate removal traps installed. This will minimize the chances of damage caused by water hammer or poor temperature control of the process due to water slugs in the steam system. Standard steam system practice is to install a steam trap every 75 feet of piping run. Ask your steam trap provider for details.
- It is recommended to have a feed water preheated system whether there is sufficient condensate return to maintain temperature or not. A feed water pre-heat system is NOT required for the MIURA boiler. However, a pre-heat of the feed water will maintain high, steady feed water temperature, reducing the amount of oxygen in the feed water and therefore the amount of oxygen scavenging chemicals required. Some chemicals used may also require maintaining a minimum temperature in the feed water tank. Please check with your chemical supply company.

### 3.3.2 FEED WATER SYSTEM PIPING

**NOTE:** Important factors to properly size the water softener are: raw water hardness, conductivity, make-up water volume, boiler operating hours and water iron content. For

**details and assistance, please contact your nearest MIURA representative or boiler water treatment chemical company.**

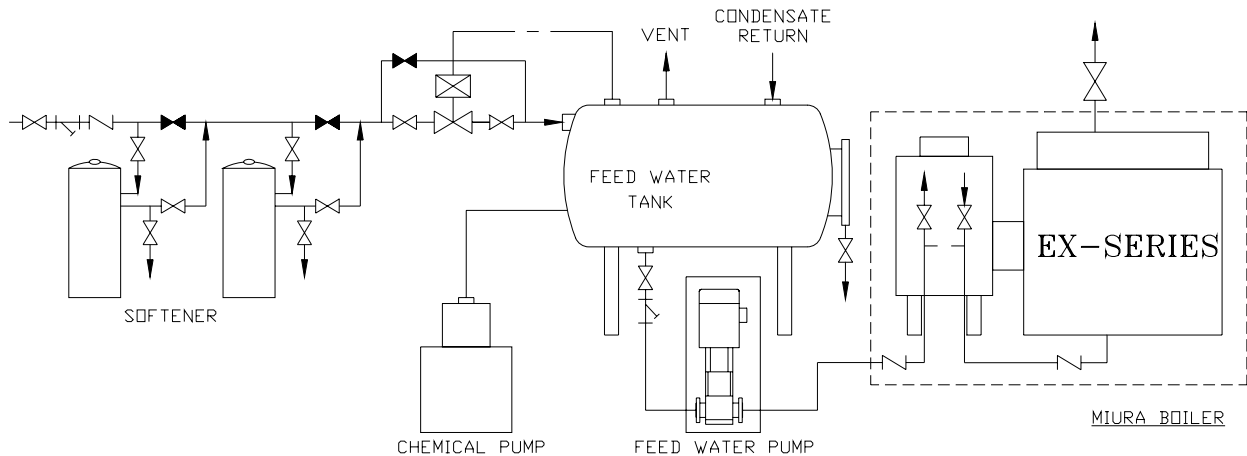

- **Zero PPM hardness and daily sampling are required at feed water tank.** Use a test kit with a minimum sensitivity of one PPM. Do not connect the hard water line to the condensate return line.
- Install softener in series, dual units are recommended. If water softeners are not installed in series, a full size polisher is recommended. Avoid a system that allows low flow rates through softener resulting in channeling of ion exchange medium. **Confirm water pressure to ensure less than 1 PPM at all times.** Typically minimum water pressure of 30 PSIG at all times is required, check with your water softener supplier for details. Use a Make up water control system that will only allow specified flow through the Softener. The rule of thumb is ½ GPM minimum flow for each 1 cubic foot of resin in the softener tank. Consult chemical treatment company for specifics.
- Test cocks for individual softener and Feed Water tank water quality testing are strongly recommended.
- Keeping a daily log of water softener, deaerator and boiler water is highly recommended.
- Collect condensate from process as feasible. Return condensate to Feed Water tank. Do not connect any piping that would allow Hardness or product to enter Feed Water tank. Thermal insulation is recommended for all piping between Feed water tank and Boiler to conserve heat.
- Run all drains and overflows to floor level with an air gap to provide inspection capability.
- Use a gate valve or ball valve in the Feed Water pump suction line followed by the specified strainer.
- Install the Feed water pump under or near the Feed water tank. The suction pipe should be adequately sized and configured to minimize friction losses. **MIURA requires at least six feet of water above the suction of the pump to prevent cavitation.** Avoid high points in the pump suction piping that would allow air to collect and result in loss of pump priming.
- Ensure the height of the water level in the feed water tank is sufficient to prevent cavitation of the feed water pump under normal operating conditions. In general, MIURA Boiler recommends installing the Feed Water supply tank as high as possible in the boiler room to prevent any possibility of Feed Water Pump Damage due to cavitation. Specifically MIURA requests that the tank water level be at least 6 feet above the pump suction.
- In some cases, a flow restricting plate may be necessary to prevent cavitation of the feed

pump when re-filling the boiler after a bottom blow down. If the boiler will not be operated over about 100 PSI, the plate may also be necessary. If the tank supplying water to the boiler is not more than 6 feet above the pump, a plate will be required.

- Dual pumps feed water systems are available as an additional option.
- Some jurisdictions require a pressure gauge on the discharge of the pump.
- Chemical feed can be made to feed tank and/or feed water line. All MIURA Boilers are provided with a set of “DRY” contacts through terminal strip connections W8 and W9. These wires connect a Normally Open contact on the feed water pump magnetic contact. MIURA recommends wiring the chemical injection pumps through this contact. This allows the chemical injection pumps to operate only when the feed pump is running. This type of operation allows the chemical company to adjust chemical usage directly to the boiler water usage. Due to the very small water content of the boiler any difference between chemical injection rate and steaming rate will result in erratic chemistry control. Operating the Chemical pumps concurrently with the feed pump will provide a more consistent use of chemicals.
- Chemical Treatment procedures should be based on recommendations of reputable boiler water chemical treatment company. NONE of the MIURA Boiler Warranties cover damage to the pressure vessel due to corrosion or formation of scale.
- Follow all local regulations.

### 3.3.3 *OPTIONAL FEED WATER PUMP*

**CAUTION:** The feed water pump is vital to satisfactory operation of your new MIURA Boiler. Review this section carefully for pump selection criteria if customer has chosen to purchase a pump from other than MIURA. All pumps, regardless of manufacturer, require a positive pressure on the pump suction to prevent cavitation damage to the pump. Any damage to the pump resulting from installation errors or cavitation is NOT covered by MIURA.

**DANGER:** MIURA Boiler is a unique design; common pump sizing criteria do not apply. Improper sizing of feed water pump will severely impact the performance of the MIURA Boiler. Under-sizing of the pump either by flow or by pressure will result in frequent Low Water Alarms and Boiler Lockouts. If this condition is allowed to continue, the Manufacturers Warranty on the pressure vessel DOES NOT COVER any tube damage that may result. Review and FOLLOW the pump sizing criteria given below and this condition will not occur.

MIURA boiler recommends that a pump be purchased with the boiler rather than using an existing pump. The reason for this is that MIURA Boilers run with intermittent feed water pump operation. MIURA Boilers start the feed pump on call for water and then turn it off when call for water stops. This is due in part to the boiler having no fixed steam/water level to maintain and in part due a side benefit of the pressure vessel design. Most boilermakers require operating the pump continuously using a modulating feed water control system such as McDonnell Miller float valves. This is done mostly to reduce thermal stresses on the boiler shell that result from

the introduction of relatively cold water to the hot boiler. It is also partly because they have a fixed steam/water level. The MIURA Design Advantage eliminates the need for this type of system. MIURA simply turns the pump on and off as needed based on actual boiler steam demand. This allows the pump to always run at optimum efficiency and prevents pump-overheating problems. The MIURA Boiler is designed, tested and CERTIFIED to operate this way. Experience has shown there is no advantage to operating a MIURA Boiler with a modulating Feed Water Control system.

Therefore, if a pump other than that provided by MIURA is used, the following selection criteria is provided: Size the pump to deliver Twice (2X) or preferably Three times (3X) the steady state evaporation rate of the boiler. This flow MUST be delivered to the boiler at a pressure AT LEAST 30-psi ABOVE the Boiler operating pressure. Also, ensure that the pump motor is able to handle frequent start/stop cycles without overheating the motor windings.

MIURA recommends using Grundfos series C multi-stage centrifugal pumps. Pumps should be installed in accordance with the manufacture’s instruction booklet in order to operate efficiently and provide years of service. The pumps are water lubricated and do not require any external lubrication or inspection. The motors will require periodic lubrication as noted in the maintenance schedule section. The pump is a close coupled, multistage high-pressure centrifugal type. Pump models vary with the horsepower of the boiler and are selected for operation at 150 PSI steam pressure on EX model. If lower pressure is desired, a flow restricting plate or smaller pump may be appropriate.

Boiler Model	Pump Desired Capacity	Grundfos Pump Model	Boiler Operating Pressure
EX-100	16 GPM	CR3-17U 3 HP	150 PSI
EX-200	32 GPM	CR5-16U 5 HP	
EX-250	40 GPM	CR10-9U 7.5 HP	
EX(N)-300	48 GPM	CR10-10U 7.5 HP	
EXH-100	16 GPM	CR3-25U 5 HP	230 PSI
		CR10-16U 15 HP	280 PSI
EXH-200	32 GPM		230 PSI
EXH-300	48 GPM		230 PSI

**CAUTION: Under no circumstances should the pump be operated without flow through the pump. Do not allow the pump to vapor lock. Severe and immediate damage to the pump will result.**

Dry operation of the pump is prohibited. This can result in motor and pump damage due to overheating. A properly sized re-circulation flow fitting may be obtained from Grundfos and installed to prevent this damage if the pump is run with an isolation valve that is closed.

MIURA boiler operations exceed the number of start/stop cycles for the pumps, which is specified in Grundfos Installation and Operating Instructions. The number of start/stop cycles in conjunction with the short running times in our application is approved by Grundfos and MIURA Boiler Engineering Department and will not result in motor overheating problems.

For detailed installation data, refer to Grundfos Installation and Operating Instructions that were supplied with the pump. The pump is in a separate crate from the boiler.

MIURA recommends installing a feed water suction strainer of at least 20 mesh. Install a strainer at least one size larger than pump suction piping. Pump flange kits are available from MIURA as an option. Also, install an isolation valve on the supply side of the strainer to allow cleaning the strainer without draining the feed water supply tank. The Suction side isolation valve and feed water strainer are NOT provided by MIURA, but must be installed in order to include the pump in the One-Year parts Warranty. The One-year warranty applies to the pump ONLY if it is purchased through MIURA.

Before starting the pump after initial installation or maintenance, please check the following:

- All piping connections are tight and the pipes are adequately supported.
- Any isolation valves on the suction of the pump are open.
- Pump is primed and vented through the vent fitting located at the top of the pump.
- Open the main powers' disconnect. Remove the coupling guard and rotate the pump shaft to be certain it turns freely. Replace the coupling guard.
- Insure that all feed water isolation valves are open.
- Shut the main power disconnect to the boiler.
- While observing the top of the pump, cycle the boiler "ON-OFF" switch located on the front of the boiler. This will start the pump and allow verification of the direction of rotation. Direction of rotation is counterclockwise when viewed from the top. The pump will not run if the control switch is in the "OFF" position.

#### 3.3.4 *OPTIONAL FEED WATER CONTROL VALVE*

In the application where the customer does not want to operate the feed pump in frequent start/stop cycles, other options are available. Again, the feed system operates in a simple On-Off manner. If control valves are used, they MUST be quick acting (within 5 seconds). MIURA recommends ball valves with pneumatic actuators (preferred) or electric actuators (acceptable). Note that the pneumatic actuators operate in 1 second open to shut and the electric actuators are 5 seconds open to shut. Electric feed water control valves are available as an option on all boiler models.

**DANGER: Any proportional feed water actuator or control valve that operates slower than 5 seconds from shut to fully open is not acceptable and will cancel all warranties.**

#### 3.3.5 *SAFETY VALVES*

Drip pans (may be supplied by MIURA if requested) should be used for boiler safety valves. Water that collects in the elbow and valve body after the valve lifts, any rainwater or valve leakage should be drained off and not allowed to stagnate. Failure to drain the water may result in valve corrosion or water hammer if the valve lifts.

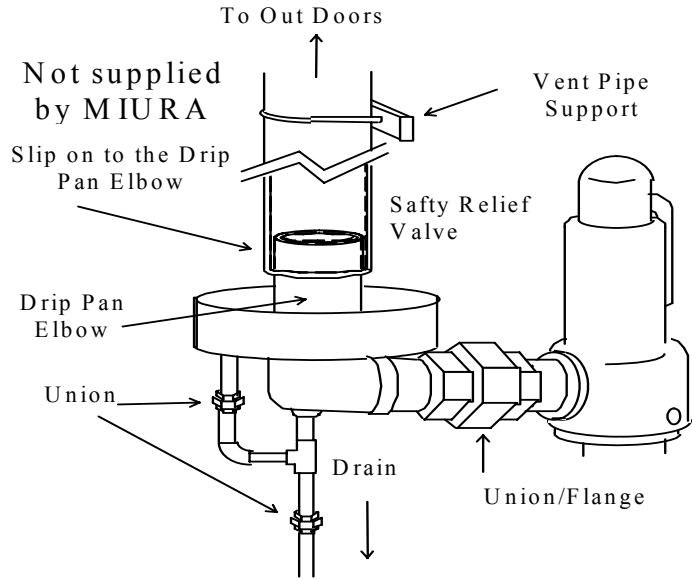
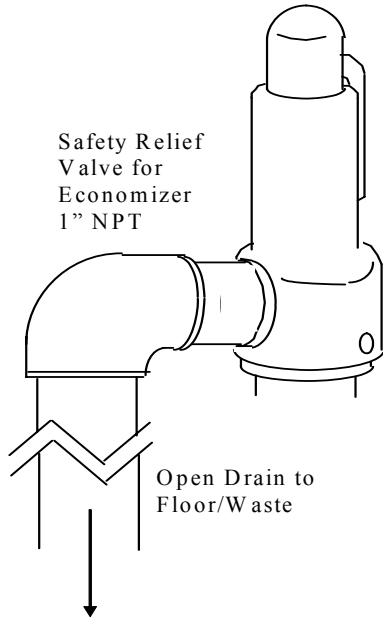

The optional economizer may be equipped from the factory with a safety valve. The economizer safety valve may not be required to be piped to the roof depending on local codes. Piping should be directed to a floor drain or other collection points as specified by the local codes concerning boiler wastewater. The water discharged by this safety may be near or at the boiling point and could cause a potential for personnel injury. Arrange the piping accordingly.

### 3.4 BLOWDOWN PIPING

	EX(H)-100	EX(H)-200	EX(H)-250	EX(N)-300	EXH-300
Blow-off Tank Minimum Diameter	18"	24"	30"		
Blow-off Tank Minimum Volume	12 cu. Ft	25 cu. Ft	42.5 cu. Ft		
Blow-off Tank Minimum Pressure	EX(N)	51 PSI			
	EXH	90 PSI	75 PSI		
Boiler Automatic Surface Blow-down Outlet	$\frac{3}{8}$ " NPT		2 x $\frac{3}{8}$ " NPT		
Boiler Manual Bottom Blow-off Outlets	1" NPT			1 1/4" NPT	1" NPT
LVC Drain Outlet	1" NPT				

Minimum dimensions and pressures of blow-off tank are based on CSA B51-95 - Boiler, Pressure Vessel, and Pressure Piping Code.

**DANGER: Be sure to install blow down piping separately from overflow and drainage piping. Piping shall be arranged to prevent any possibility of water splashing and causing personal**

**injury.**

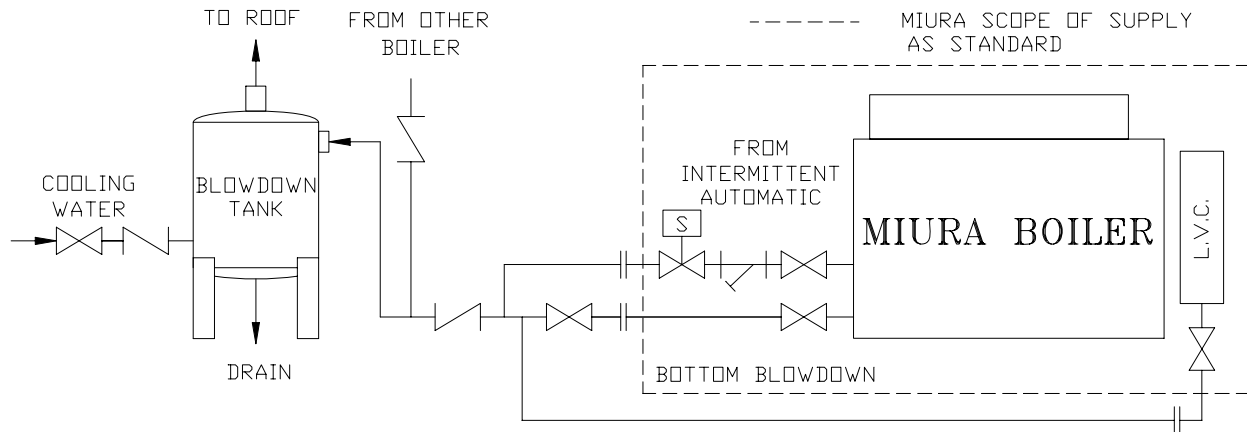

All piping subject to pressure from the boiler during blowdown must be securely anchored to prevent piping vibration and shock during blowdown of the boiler. Due to the large number of different piping arrangements possible, MIURA recommends a maximum pressure for manual bottom blowdown of 30 PSI.

**DANGER:** Note that the Automatic Surface blowdown line operates automatically when the boiler is at high pressure and temperature. Therefore the  $\frac{3}{8}$ " pipeline must be piped to the blowdown tank to avoid personal injury.

Do not allow siphoning back into the boiler from wastewater drains.

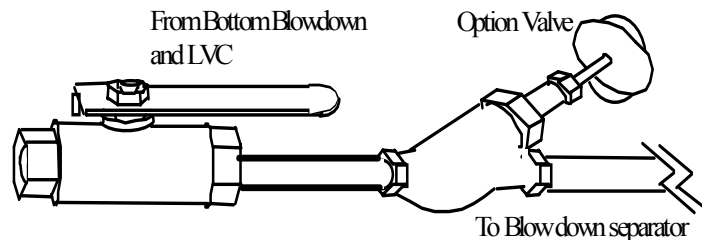

Standard equipment includes one quick opening ball valve for blowdown isolation. Additional "Y" pattern slow opening blowdown isolation valves may be installed at customer request and as required by local regulations.

MIURA recommends installing an additional check valve between the automatic blowdown solenoid valve and the blowdown separator. Check valve is not included with boiler.

A blowdown vessel or Miura Blowdown Separator shall be placed between the boiler and sewer, where the blowdown from any boiler having a working pressure exceeding 15 PSI is discharged into a sewer system. This is to reduce the temperature of water entering the sewer system to a maximum of 150°F. MIURA Boiler may supply Blowdown separator after cooler control at customer request. Ensure that local regulations for disposal of boiler wastewater are followed.

In an installation where multiple boilers share a common blowdown separator, install a check valve in the piping between each automatic and manual blowdown isolation valve and the blowdown separator.

In a situation where all blowdown water is collected in a sump, size the sump for at least five times the operational water content of the boiler. This will allow collecting the boiler water and the cooling water used by the blowdown separator. The operational water content is provided in the general specification tables.

Follow all local regulations.

### 3.5 FUEL PIPING

#### 3.5.1 GAS PIPING

FUEL TYPE: Natural Gas or Propane Gas  
 SUPPLY PRESSURE: 3 - 5 PSIG \*

**NOTE:** 3 – 5 PSIG is the setting range, NOT the allowable fluctuation range. Maintain steady, set gas supply pressure within 0.2 PSIG but NEVER below 3 PSIG during operation. This pressure must be at the regulator supplied with MIURA Boiler gas piping. If necessary, use larger pipe for long piping runs. Failure to maintain required gas flow rate pressure will result in frequent boiler misfire!

**NOTE:** Do not use any gas piping with a diameter smaller than the gas inlet piping to boiler. All main gas train piping to the burner is included, (except for individual regulator and pressure switch vents).

**CAUTION:** Do not attempt to change any part of this gas train without first consulting the nearest authorized MIURA representative.

	100	200	250	300
Gas Inlet	2" NPT		2 ½" NPT	
Main Regulator Vent	1" NPT			
Pilot Regulator Vent	1/8" NPT			
Pressure Switches	2 x 1/8" NPT (some switches model may not require vent)			
Option Automatic Vent	1" NPT		1¼" NPT	

See specification tables for fuel consumption.

Supply pressure of 3 to 5 PSIG is required at boiler regulator inlet at full firing rate and when boiler combustion is stopped. Installation of a pressure gauge to monitor gas supply pressure is recommended. If the boiler is operated with propane fuel, MIURA Boiler STRONGLY recommends the use of a vaporizer. Collecting the propane gas from the top of the tank is possible, but not recommended due to variations in vapor space pressure depending on ambient air temperature. Also, ensure the vaporizer is sized for full boiler capacity even if the normal load is less than the maximum capacity of the boiler. This recommendation is based on the boiler operating at full rated fuel flow during the start up period.

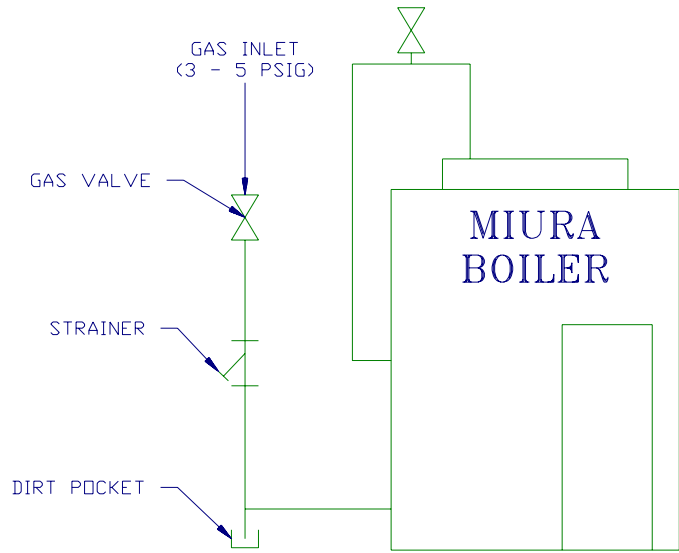

If the supply gas pressure is above 5 PSIG, use only one approved reducing station per boiler room to meet the required specifications. Do not use a separate reducing valve to supply each boiler. This would result in pressure oscillations that could result in boiler flame failures or momentary over firing conditions. Consult pressure regulator application engineers for correct sizing and regulator model selection. Use an approved booster pump, if necessary, to meet the required minimum pressure specifications. To ensure an adequate volume of fuel is available to support combustion during firing rate changes, a 3 PSIG minimum is required at the inlet to the boiler main regulator supplied with the boiler. Specifically, a change from burner Off to Low Fire, which is approximately 40% of rated fuel usage, occurs over a 10 - 15 second period. The fuel usage then goes from 40% to 100% rated consumption when the boiler goes to high fire. This change occurs in less than one second. Fuel consumption then changes from 100% to zero in less than one second when the boiler turns off. The utility gas regulator must maintain at least 3 PSIG and not exceed 5 PSIG under these conditions, and is to be installed as far away from the boiler regulator as possible. The maximum pressure of 5 PSIG is determined by UL and CSA approval of the MIURA standard gas train. Consult gas company for details.

The Copper gas line to the pilot regulator is tin lined and does not require replacement in jurisdictions that prohibit use of Copper tubing on natural gas piping. The pilot gas regulator is required to be vented outside. Do not allow line to be crimped; frequent pilot flame failures will result.

Install dirt pocket on Main gas inlet piping immediately up stream of boiler.

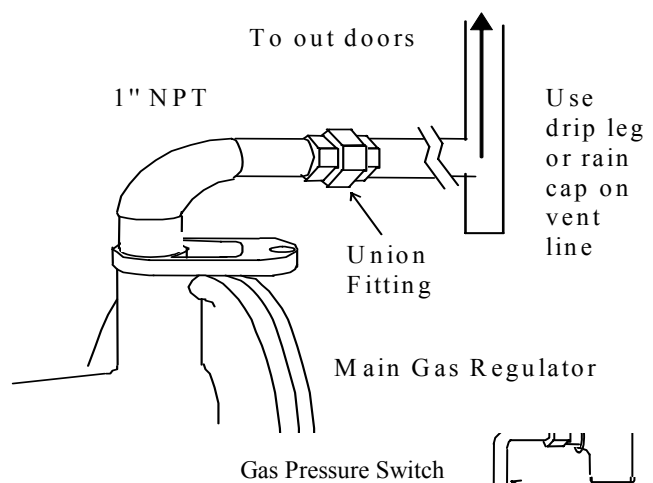
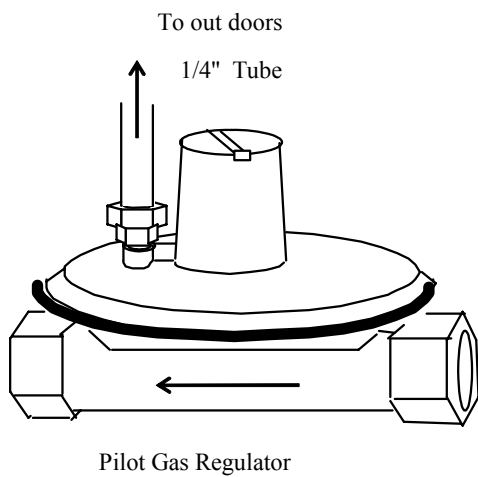
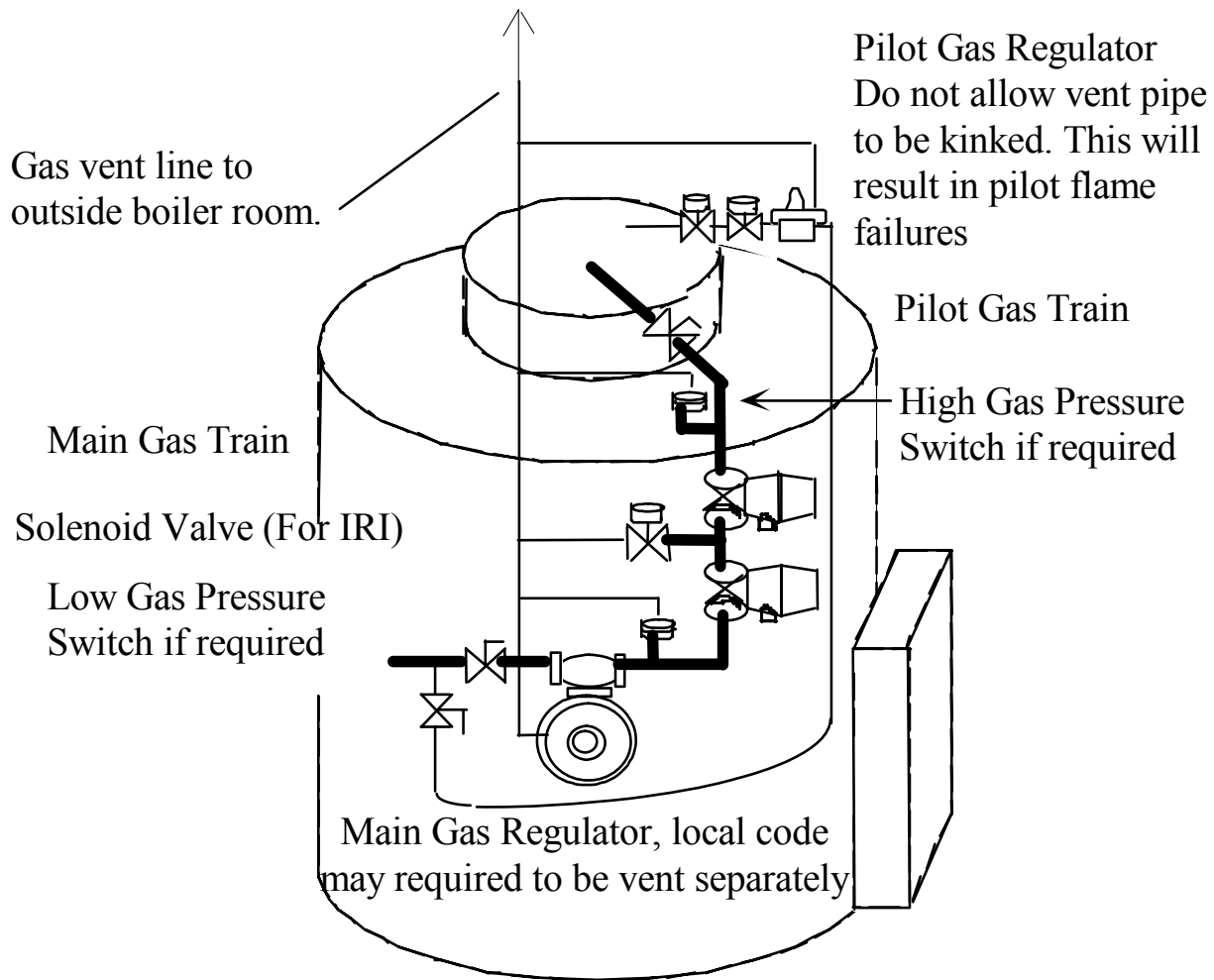

Two pressure switches, HIGH and LOW gas pressure,

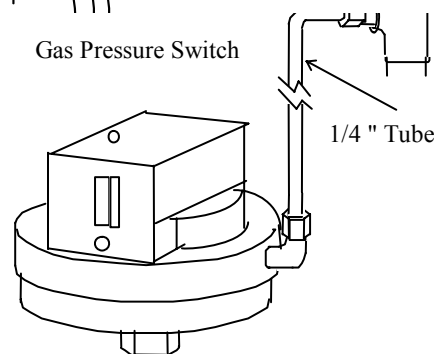

may be required to be vented to the atmosphere outside of the boiler room. Contact your local insurance provider and the Gas Company for specific requirements. Note that some boiler models may have ANTUNES RLGP-G 5~30' switches on the gas train which do not require venting to the atmosphere.

Typically, gas vent lines can be connected to a common vent line. The vent line will have a cross-sectional area not less than the area of the largest vent line, plus 50 percent of the areas of all the additional vent lines.

An optional solenoid automatic vent valve located between the main gas blocking valves may be required for insurance purposes and is an additional cost option to meet IRI specifications. Ensure IRI is specified on the purchase order if necessary.

Follow all local regulations.

### 3.5.2 OIL PIPING

FUEL TYPE: No. 2 Oil

**NOTE:** All EX oil-fired boilers (except EX-100) require Natural or Propane gas for pilot burner ignition.

**CAUTION:** Do not attempt to change any part of this oil train without first consulting the nearest authorized MIURA representative.

	100	200	250	300
Oil Inlet	3/4" NPT			

- All oil piping to the burner is included
- Install a manual fuel oil shut off valve at the boiler.
- In order to comply with National Fire Protection Code, the fuel pump suction pressure should not exceed 3 PSIG.
- Fuel pressure at pump suction must NOT be at a vacuum. Do not use the MIURA supplied oil pump to draw oil up from the tank, through the overhead, and down to the boiler. This arrangement almost always allows air to leak into the pump suction connection and results in very poor combustion.
- Avoid high points in the pump suction piping that would allow air to collect and result in loss of pump priming. Do not pipe from

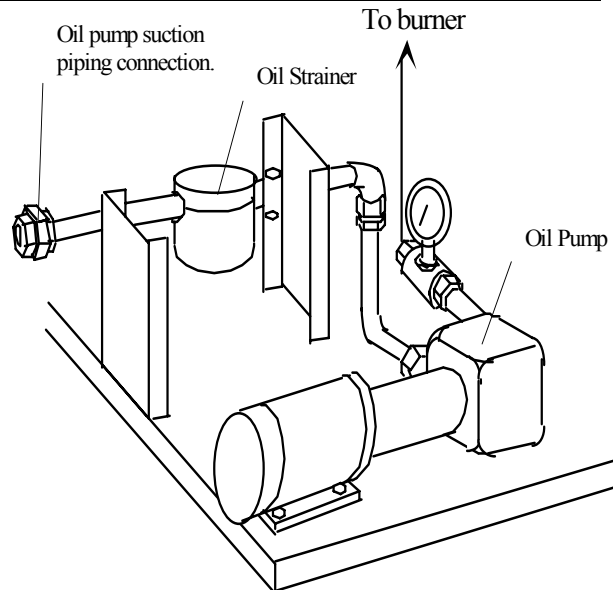

oil tank to ceiling and down to boiler without an air vent or air lock will occur. Piping along the floor is preferred.

- To prevent loss of Oil Pump priming, it may be necessary to install a re-circulation pump.
- Vent all air from the piping to prevent damage to the oil pump seal before running the pump.
- Follow all local regulations.

### 3.6 CLEARANCES & VENTILATION

#### 3.6.1 CLEARANCES

The EX model is designed for non-combustible floors with minimum clearances from the unit and flue connector to combustible materials of:

Boiler Top	40 inches	(1,020mm)
Boiler Side	24 inches	(610mm)
Boiler Rear	24 inches	(610mm)
Boiler Front	48 inches	(1,220mm)

Follow all local regulations.

#### 3.6.2 VENTILATION

The table below gives factory recommended minimums for ventilation of each boiler. The recommendation is based on Canadian Gas Association standards. However, please confirm with local building and safety codes as boiler room ventilation requirement vary by significant amounts. For multiple boiler installations, multiply the below areas by the number of boilers installed in the boiler room.

	SUPPLY AIR AREA (Sq. in.)	VENTILATION AIR AREA (Sq. in.)	CHIMNEY DIAMETER (inches)
100	140	14	14
200	280	28	20
250	345	35	20 (26 for FGR)
300	415	41	26

Ventilation of space occupied by boiler should be provided by at least one opening directly in contact with the outdoors. Such an opening is to be located at the highest practical point for the purposes of generating natural convective processes of air circulation. The total cross-sectional area of such openings shall be at least equal to those in the table above.

In addition to the required opening for required air ventilation, there should be a permanent air supply via openings having a total cross-sectional area not less than what is required from table above. The location of these openings shall not interfere with those openings intended for the purposes of ventilation. These air supply openings should be either located at, or ducted to, a point

not more than 18 inches (450 mm), nor less than 6 inches (150 mm), above the floor level.

### 3.7 STACKS AND BREECHING INSTALLATION

**NOTE: Consultation with your Engineering Company or Exhaust Stack provider will ensure a long lasting trouble free stack design. The stack must be designed to maintain available draft at the outlet of the boiler between zero to -0.05" of water throughout the whole firing range (i.e. for four boilers; all boilers at high-fire or only one boiler at low-fire). Failure to maintain this value will adversely affect boiler performance and is not the responsibility of MIURA.**

Each boiler should be equipped with a single stack. If this is not possible, Barometric dampers or equivalent are required to prevent exceeding maximum draft on the boiler.

Proper installation of the chimney is required for good boiler efficiency and safe operation. The following principles should be followed at all times when designing chimneys.

1. Chimneys should be straight. Bends or offsets have more resistance to flow with consequent adverse effects on burner performance and should be avoided whenever possible.
2. A stack should be higher than nearby structures to avoid down drafts or eddy current. If this is not possible, a stack hood designed to prevent downdrafts should be considered.
3. The stack should project at least:
  - a) Two feet above the horizontal plane drawn from a point at least 10 feet away from the stack; and
  - b) Three feet above the lower side of the roof slope.

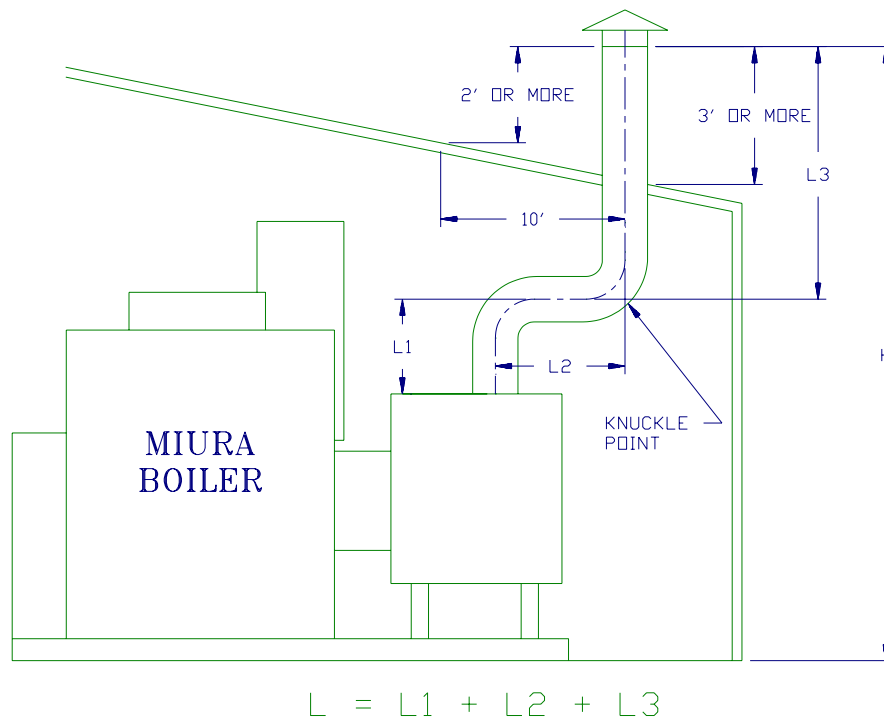

4. Include a rain hood for all stacks. In addition, be sure to add a rain shield for straight stacks through the roof.
5. Do not make the stack diameter smaller than the flue gas outlet on the boiler.
6. Provide supports if the stack exceeds 100 lbs. Also, clamp the stack firmly to the flue gas outlet.
7. Install the stack away from any combustible materials and utilize insulation at the opening in the wall or roof. Flue gas sample fittings are provided from the factory on boilers ordered with economizers. In addition, the flue drain connections are provided on the exhaust elbow or economizer. Ensure these connections are piped to drains. Please do not cover these fittings when insulating the exhaust stack.
8. One, ½” drain plug fitting is installed on the optional MIURA flue elbow and one, 2” drain coupling is provided on the optional economizer. The 2” drain coupling is intended to allow piping of condensation to a floor drain through a “J” type water trap. Do not connect these drain holes with any blowdown piping.
9. When the boiler is installed in regions where temperatures fall to the freezing point, a stack damper should be installed to prevent down drafts from freezing the boiler tubes when it is not in operation. In addition, a chimney down draft will have a direct effect on main burner ignition reliability.
10. Follow all local regulations. Check your building, fire and mechanical codes as a minimum guideline.

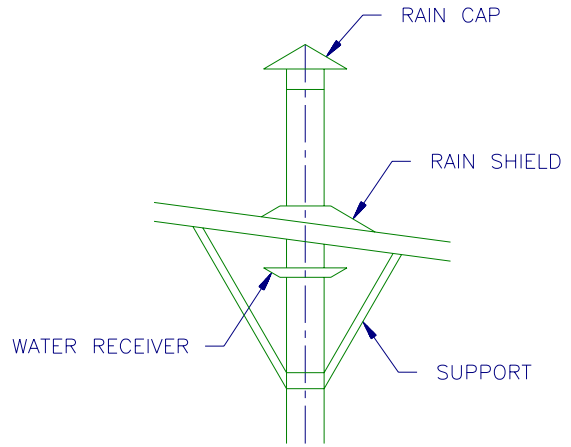

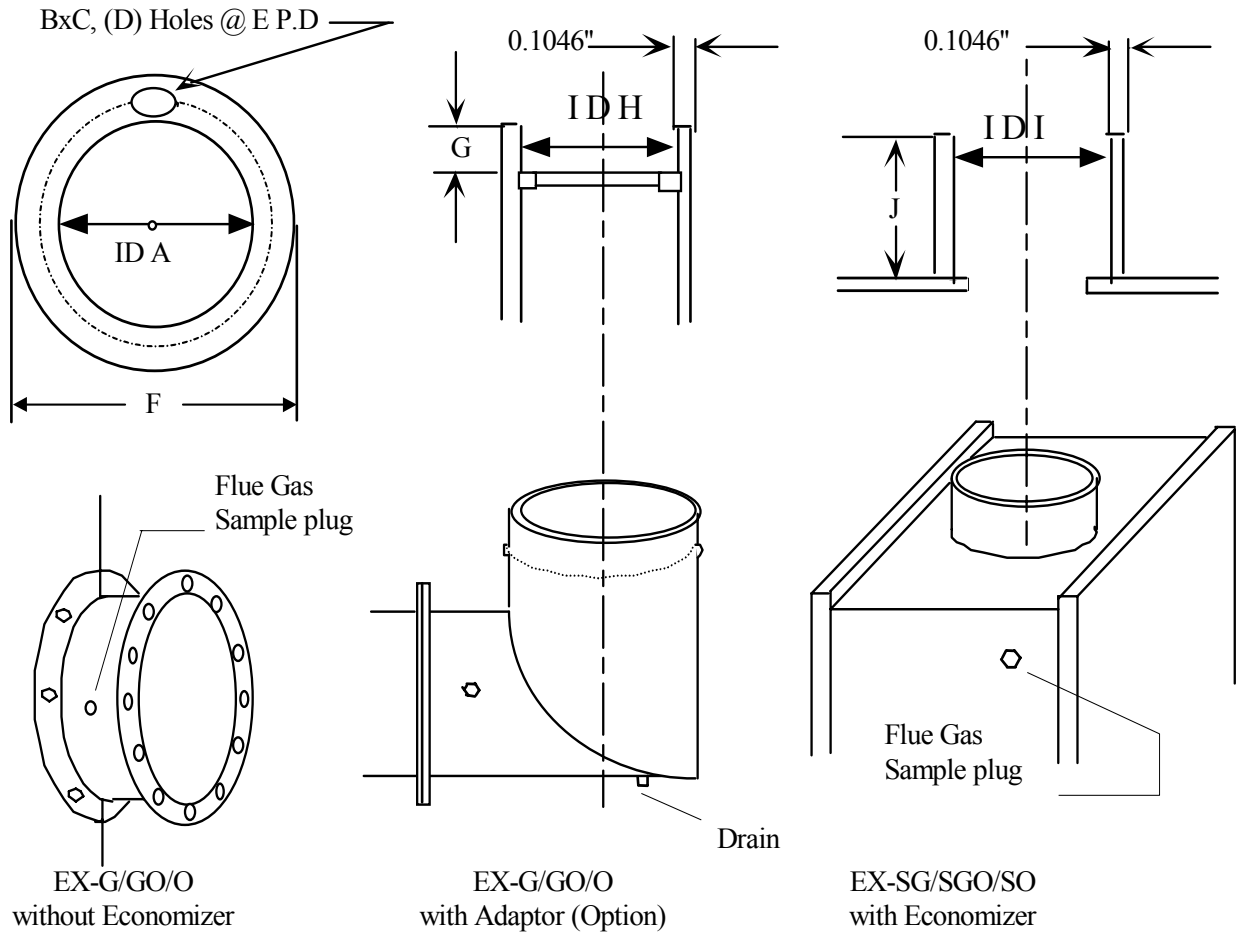

## FLUE GAS OUTLET DIMENSION

	Without FGR				With FGR			
	100	200	250	300	100	200	250	300
A	13½"	19½"		25½"	13½"	19½"	25½"	
B x C	5/8" x 1 1/8"							
D	12	16			12	16		
E	16"	22"		25½"	16"	22"	25½"	
F	18"	24"		30"	18"	24"	30"	
G	1½"				N/A			
H	14"	20"		26"	N/A			
I								
J	4"	6"			N/A			

The equation below states the relationship between chimney draft and pressure drop of flue gas.

$$0.82H > 0.49L + 1.5N + 1.5$$

$$0.25H > 0.15L + 1.5N + 1.5$$

H: Height of chimney end (Ft)  
 L: Total length of chimney (Ft)  
 N: Quantity of knuckle points.

H: Height of chimney end (m)  
 L: Total length of chimney (m)  
 N: Quantity of knuckle points.

Please ensure the above equation is satisfied in order to obtain the full capacity of the EX-Series.

## STANDARD EMISSION FOR MIURA EX SERIES BOILER

	Stack Temperature	O <sub>2</sub>	NO <sub>x</sub>	CO	Smoke
EX-G	500°F	5% ± 1%	< 100 PPM	< 300 PPM	N/A
EX-SG	300°F				
EX-O	500°F	7% ± 1%	< 120 PPM	< 300 PPM	≤ #2
EX-SO	300°F				
EX-SGF	300°F	5% ± 1%	< 49.6 PPM	< 300 PPM	N/A
EX-SOF	300°F	7% ± 1%	< 80 PPM *	< 300 PPM	≤ #2
EXN-SGF	300°F	5% ± 1%	< 30 PPM	< 300 PPM	N/A
EXN-SOF	300°F	7% ± 1%	< 90 PPM *	< 300 PPM	≤ #2

- These data are based on shop test boiler with 70°F feed water temperature and 70 PSI steam pressure at high-fire rates. NO<sub>x</sub> and CO are corrected to 3% O<sub>2</sub> based on Natural Gas and No. 2 oil combustion.
- Optional <72.3 PPM NO<sub>x</sub> for EX-SOF is available.
- On oil fire, SO<sub>x</sub> is normally less than 20 PPM and depends on oil type.

### 3.8 ELECTRICAL INSTALLATION

**NOTE:** MIURA recommends that an Alarm or Caution light be installed in the control room if possible.

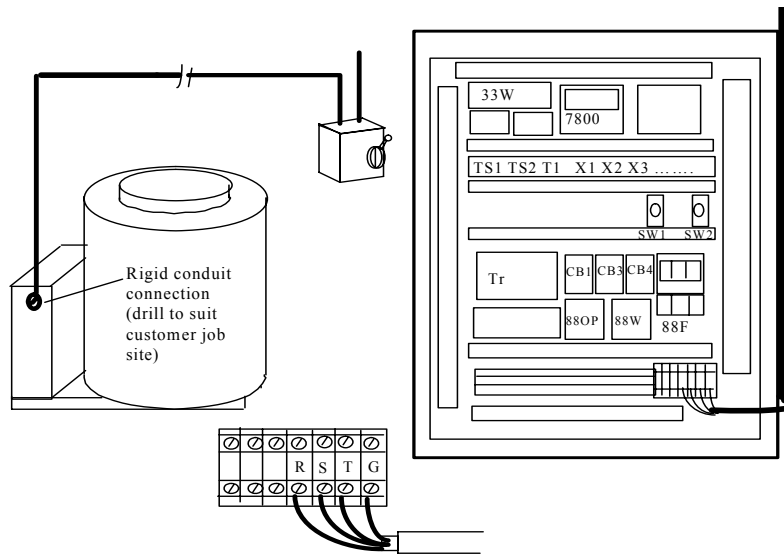

- Optional equipment such as MIURA Multiple Installation (MP1/MT1-200) system must be wired as specified in the individual instruction books.
- After installation of the feed water pump and blower to the foundations the motors must be wired to the boiler power distribution box, using customer provided cables. If the pump or blower is located some distance from the boiler, an emergency stop/start or disconnect switch may be required near the motors. Check rotation direction of blower, feedwater pump, and oil pump.
- Comply with local building electrical codes.

		Without FGR			With FGR		
Voltage (V)		575	460	230	575	460	230
Input Rate (A)	EX-100	15.5	18.0	35.0	21.9	27.8	54.6
	EX-200	24.7	31.3	61.6	29.7	36.6	73.2
	EX-250	31.6	39.6	79.2	31.6	39.6	79.2
	EX-300	31.6	39.6	79.2	48.0	57.4	123.2
	EXN-300	N/A			35.7	43.8	82.4
	EXH-100	17.3	20.3	39.6	N/A		
	EXH-200	29.0	37.3	72.6			
	EXH-300	39.7	48.4	97.8			
Electrical Consumption (KVA)	EX-100	13.0 (14.3 Oil fired)			22.2 (23.1 Oil fired)		
	EX-200	24.0 (24.9 Oil fired)			28.2 (29.2 Oil fired)		
	EX-250	30.4 (31.6 Oil fired)					
	EX-300	30.4 (31.6 Oil fired)			43.9 (45.7 Oil fired)		
	EXN-300	N/A			31.4 (33.0 Oil fired)		
	EXH-100	14.8 (16.2 Oil fired)			N/A		
	EXH-200	28.8 (29.7 Oil fired)					
	EXH-300	36.7 (38.6 Oil fired)					
Wire Gauge (AWG)	EX-100	#10x3 + #14(G)		#8x3 + #10(G)	#8x3 + #10(G)		#4x3 + #8(G)
	EX-200	#8x3 + #10(G)		#3x3 + #8(G)	#8x3 + #10(G)	#6x3 + #8(G)	#2x3 + #8(G)
	EX-250	#8x3 + #10(G)	#6x3 + #8(G)	#2x3 + #8(G)			
	EX-300				#6x3 + #10(G)	#4x3 + #8(G)	
	EXN-300	N/A			#8x3 + #10(G)	#6x3 + #8(G)	#2x3 + #8(G)
	EXH-100	#10x3 + #12(G)		#6x3 + #10(G)	N/A		
	EXH-200	#8x3 + #10(G)	#6x3 + #10(G)	#4x3 + #8(G)			

		Without FGR			With FGR		
Voltage (V)		575	460	230	575	460	230
	EXH-300	#8x3 + #10(G)	#6x3 + #8(G)	#2x3 + #6(G)			
Disconnect Amperage (A)	EX-100	30	30	60	30	40	60
	EX-200	30	40	80	40	40	100
	EX-250	40	60	100	40	60	
	EX-300				60	60	
	EXN-300	N/A			40	60	100
	EXH-100	30	30	60	N/A		
	EXH-200	40	60	80			
	EXH-300	40	60	120			

**CAUTION: MIURA boiler is supplied with a motor controller for the boiler feed water pump. The optional feed water pump should be powered from the boiler. If the pumps and motor controller were supplied with the de-aerator or hotwell tank, use the two terminals identified on wiring diagram as the remote ON-OFF switch for the pump. The feed water pump should be located as close as possible to the water source to minimize risk of cavitation.**

## SECTION 4 OPERATION

**DANGER:** All cover plates, enclosures and guards must be in place at all times, except during maintenance and servicing.

**CAUTION:**

- This is a shop tested, assembled and fully packaged boiler. Each unit and assembly has been well adjusted at the factory. It is very important not to make any adjustments without first consulting your nearest authorized MIURA dealer.
- Daily water analysis should be performed to see if additional treatment is needed. Use a tester of 1 PPM or less sensitivity.

**NOTE:** See MIURA XJ1 manual for detailed operation of the control panel.

### 4.1 PREPARATION BEFORE START-UP

Check the following **everyday** before boiler start-up:

- a) Make sure all gauges are operating correctly.
- b) Make sure there is water in the feed water tank (hotwell or deaerator)
- c) Make sure boiler water is conditioned (for instructions on checking for soft water, refer to your water softener instruction manual).
- d) Make sure there are chemicals in the chemical feed tank.

### 4.2 START-UP

**CAUTION:** The following start-up routine must be followed in sequence.

- a) Open feed water inlet valves.
- b) Open the main fuel valve (gas or oil) and check that the required gas pressure (3 - 5 PSIG) on gas firing or oil level on oil firing is available. Then select fuel switch in control box.
- c) Turn the power source on. The "OPERATION" switch on the control panel will illuminate. The display on the panel will show "DISABLE" and steam pressure.
- d) Make sure the manual blow-off valves are closed.
- e) Turn the "OPERATION" switch to "ON" and the display on the panel will show "ENABLE". The feedwater will also be running until the water volume inside boiler meets the requirement for startup.
- f) Once the feedwater pump has stopped, push the "COMBUSTION ON/OFF" button. After a pre-purge cycle, combustion will begin automatically.

**NOTE:** If the water volume is low or boiler steam pressure is high, the display on the panel will show "STANDBY". If there is anything wrong with any of the "INTERLOCK" sensor, the display on the panel will show "ALARM" with the alarm condition and the alarm will sound

after pushing the "COMBUSTION ON/OFF" button.

g) Combustion sequence to full fire for all EX-100 oil fire is as follows:

- 1) Pre-purge
- 2) Low fire main burner ignition
- 3) Low fire main burner confirmation
- 4) High fire main burner (if required)

Combustion sequence to full fire for all other boilers is as follows:

- 1) Pre-purge
- 2) Pilot gas ignition
- 3) Pilot flame confirmation
- 4) Low fire main burner ignition
- 5) Low fire main burner confirmation
- 6) Pilot gas shut-off
- 7) High fire main burner (if required)

h) When desired steam pressure is reached, slowly open the steam outlet valve.

### 4.3 BLOWDOWN AND BLOW-OFF

#### 4.3.1 AUTOMATIC SURFACE BLOWDOWN (STANDARD)

Blowdown systems are primarily operated "continuously" to control the concentrations of dissolved solids in boiler water. MIURA boiler automatic surface blowdown works on conductivity of water and evaporation rate.

#### 4.3.2 MANUAL BOTTOM BLOWOFF

**CAUTION: During Blow-off:**

- a) Be sure the main steam valve is closed before beginning blow-off.
- b) Do not perform blow-off with steam pressure over 30 PSIG unless the Blowoff piping is specifically designed for higher pressure.
- c) Blow-off the boiler on start-up rather than just after shutdown whenever possible. This will maintain boiler chemicals and pH in boiler while it is shutdown. In addition, do not manually blow-off during operation. Manual Blowoff during operation may result in boiler shut down due to low water content.
- d) Since the number of full blow-off is dependent upon running hours and water quality in your area, please follow the advice of the nearest MIURA distributor or water treatment representative.

Blowoff systems are operated intermittently to remove accumulated sediment from the boiler and/or piping, or to lower boiler water level in a rapid manner. **It is recommended that blowoff be performed daily just after start-up:**

- a) Close the main steam valve, raise the steam pressure to 20 - 30 PSIG, and push the "COMBUSTION ON/OFF" button. Combustion will stop and post-purge will begin. Turn the "OPERATION" switch to "OFF" after post-purge.

- b) Open the blow-off valves slowly and begin blow-off.
- c) Since the frequency of full Blowdown is dependent upon running hours and water quality in your area, please follow the advice of the water treatment representative.
- d) Continue the blow down until the boiler is completely dry. This will ensure all sludge is removed. Complete draining of the MIURA boiler is not dangerous to the boiler. Once blow-off is complete (takes only 3 to 4 minutes), close the blow-off valves and repeat start-up routine in Section 4.2.
- e) When required steam pressure is reached, **slowly** open the main steam valve.

### 4.3.3 *AUTOMATIC BOTTOM BLOWOFF (OPTION)*

This is optional equipment and only recommended when the boiler feed water **has no hardness** and the silica is removed. The water must also be free of any thick sludge and a non-precipitation hardness modifier is used. Phosphate treatment is **not recommended**. Please discuss this further with your water treatment supplier of chemicals.

- a) The optional automatic blowoff valve will reduce the manual full blowoff sequence of the boiler to up to two weeks depending on water conditions.
- b) The bottom blowoff valve automatically opens for 30 seconds every 60 seconds of High Fire combustion time. The frequency of blowoff is determined by the quality of the feedwater. The feedwater quality to be maintained must be less than 0.5 PPM of hardness. Also the **boiler water quality** must be maintained, so that the boiler water conductivity is kept below 4,000 mmhos. The automatic bottom blowoff valve will not open unless the feedwater pump is OFF and water volume is normal.

**DANGER: The optional automatic blowoff valve and piping arrangement must be secured properly, as this line will be under full operating steam pressure.**

**CAUTION: A full manual blowoff must be conducted at least once every 2 weeks to prevent scale build up.**

## 4.4 SHUTDOWN

**CAUTION: The following shutdown routine must be followed in sequence.**

- a) Push the “COMBUSTION ON/OFF” button. Combustion will stop and post-purge will begin.
- b) Once post-purge has finished, turn the "OPERATION" switch to "OFF" position.
- c) Close all feed water inlet and outlet valves.
- d) Close the fuel valves.
- e) Turn off the main power supply to the boiler.
- f) After prolonged shutdown, follow start up procedure to restart the boiler.

## 4.5 CAUTIONS DURING OPERATION

**DANGER: The following points MUST be followed to avoid damage or injury**

- a) Always open the main steam outlet valve **slowly** to prevent carryover and water hammer.
- b) If there is a misfire or flame failure, locate the cause of the problem, (as discussed in Section 5.3 - Troubleshooting) fix it, push the "COMBUSTION ON/OFF" button, then push the reset button on the display and re-start the boiler. If the same problem persists, shut the boiler down and call the nearest MIURA representative or distributor.
- c) Whenever fuses need replacing, use only specified ratings. When replacing a circuit breaker or magnetic contactor, ensure that trip settings are set correctly on the new component.
- d) If the circuit breaker tripped, check it, and then reset it. In this case, re-test the low water interlock by blowing off as described in the section of blowoff. If the alarm does not sound when tested, see Troubleshooting Section. If the circuit breaker trips again, shut down the boiler. Call an electrician or nearest MIURA representative or distributor.
- e) Proper balance of gas and airflow is needed to assure complete combustion and optimum efficiency. Adjust the airflow as needed. MIURA recommends a combustion tune up every three to four months to maintain optimum efficiency due to air temperature and humidity changes every season. Contact your nearest MIURA representative or distributor to adjust air flow.
- f) Do not change the setting on the high-pressure limit or over heat protection.
- g) When unsure of any boiler trouble, shut down the boiler, turn the power source off and contact your nearest MIURA representative or distributor.
- h) **If you smell gas, immediately shut down the boiler, turn off all power sources, and close all main gas valves.** Immediately locate and repair the source of leak, and contact your gas company and then a MIURA representative.
- i) Be careful when you take a sample of water from the boiler. Please be sure to open the valve very **slowly**. A water sample cooler is strongly recommended.
- j) **Do not re-light pilot or start burner with the combustion chamber full of gas or with a very hot combustion chamber.**
- k) **In an emergency, push the "COMBUSTION ON/OFF" button to stop combustion and close the GAS VALVE first, then cut out the main power supply to the boiler.**
- l) As sludge or dirt may possibly affect the performance of the automatic solenoid blowdown, it should be checked periodically to confirm proper operation.
- m) Do not close the feed water valves to the economizer (if applicable). Only in the event of an economizer problem, should the bypass valve be used.
- n) If frequent Low Water Level alarms occur, clean all Water level probes and the feed water strainer prior to calling for service on the boiler. Dirty probes cause over 90% of the Low Water Alarms.
- o) For dual fuel boiler, make sure to close the main fuel valve of the fuel that is not in use, before starting the boiler. Also check to make sure neither main fuel valve of that fuel train is open during main combustion.

## 4.6 SAFETY ATTACHMENTS

### 4.6.1 LOW WATER VOLUME CUT-OFF

If the water volume, for any reason, falls below the pre-determined water volume, combustion will immediately be stopped and a warning alarm will be activated. The display will read, "ALARM" and "LOW WATER LEVEL".

After complete blowdown of the boiler, all the red lights on the floatless switches will be off. With the main power turned on at the boiler and the "OPERATION ON/OFF" switch "ON", the feedwater pump will start. After a few minutes, the red LED of floatless switch #33WL1 will illuminate. Then the red LED of the floatless switch #33WL2, will come on. The feed water pump will continue running until the required water volume for start up is met. At this point, the feed water pump will stop. If the red LED of any floatless switch does not come on in the above sequence, please check the electrodes and wiring to the electrodes.

Probe	Wire	Switch contact	Function
Longest on LVC	E1 (red)	33WL1	Low water cut off
Medium on LVC	E2 (white)	CPU (5)	Pump control
Shortest on LVC	E3 (blue)	CPU (7)	Pump control
Longest in boiler	E4 (orange)	33WL2	Secondary LWC
Shortest in boiler	E5 (brown)	CPU (7)	Secondary control
In separator	E6 (gray)	33WH	Option High water
In return pipe	E8 (purple)	CPU (12)	Conductivity control

For testing the Low Water Volume Cut-off, open the ball valve at the bottom of the LVC and allow time for the steam pressure to force the water out of the LVC (about 5-10 seconds). When the low water cut-off probe loses contact with the water, the boiler will shut down, the alarm will sound and the XJ1 Microcomputer will display "LOW WATER CUT-OFF".

### 4.6.2 OVER HEAT MONITOR TEMPERATURE

If the temperature of the overheat thermocouple on the water tubes should, for any reason rise above the pre-set temperature, the XJ1 Microcomputer will shut down the boiler, activating the alarm. The display will also show "HIGH W TUBE TEMP".

For testing these functions, use the "Set Clock" menu. Record the present setting temperature then set it to lower than the tube temperature. It will shut down the boiler when the tube temperature reaches the new preset value. We suggest changing only the hundreds value. After testing, do not forget to reset to original setting or the boiler will not run.

### 4.6.3 SCALE MONITOR TEMPERATURE

If the temperature of the scale monitor thermocouple on the water tubes should, for any reason rise above the pre-set temperature, the XJ1 Microcomputer will shut down the boiler, activating the

alarm. The display will also show “SCALE WARNING”. Note that there are two different settings for the scale monitor alarm. One setting is used during High-fire and other during Low-fire. The XJ1 Microcomputer will wait 40 seconds after change in firing rate to evaluate the current tube temperature against the alarm set point. It also adjusts the alarm set point internally based on boiler steam pressure. **Do not change these settings from the factory numbers.**

For testing these functions, use the “Set Clock” menu. Record the present setting temperature then set it to lower than the tube temperature. It will shut down the boiler when the tube temperature reaches the new preset value. We suggest changing only the hundreds value. After testing, do not forget to reset to original setting or the boiler will not run.

**CAUTION: Should the high temperature alarm ever be activated, immediately contact your nearest authorized MIURA representative and chemical company. DO NOT restart the boiler or change the setting without written authorization or pressure vessel may be severely damaged.**

#### 4.6.4 HIGH PRESSURE LIMIT CUT-OFF SWITCH

If the boiler pressure should for any reason rise above the pre-set pressure, the High Pressure Limit Switch will be activated, the boiler will shut down, and the alarm will sound. The display will show "ALARM" and “EMERGENCY STOP”.

If the boiler shuts down due to high pressure, you need to press the reset level on the pressure switch to restart the boiler. Please check the pressure transducer and setting of the XJ1 Microcomputer as well as the Control Pressure switch for any malfunction or wrong setting. The Control Pressure switch should have a lower setting than the High Pressure Limit switch, and the Microcomputer should have a lower setting than both steam pressure switches.

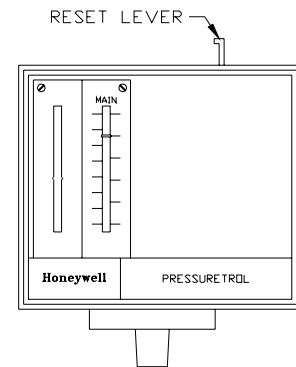

For testing the High Pressure Limit switch, set it lower than the XJ1 Microcomputer setting. It will shut down the boiler when the boiler pressure reaches the set pressure. After testing, be sure to set it back to the original setting and reset the High Pressure Limit switch.

#### 4.6.5 MISFIRE

If ignition is not achieved after the ignition period, burner operation will immediately be stopped. After a purge cycle, the safety switch of the Flame Safeguard will be activated, a warning alarm will sound, and the display will show "ALARM" and “FLAME FAILURE”.

For testing the Flame Safeguard, close the pilot gas valve, and then start the boiler. Misfire will occur after first or second attempt for pilot. After testing, do not forget to open the pilot valve and reset the XJ1 Microcomputer.

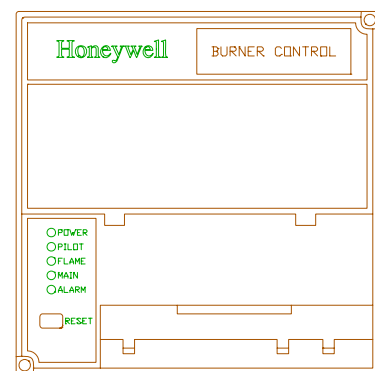

#### 4.6.6 FALSE SIGNALS

Should there be any false signals emitted during ignition, pre-purge, or should pre-purge timing be off, the safety switch of the Flame Safeguard will be activated, the boiler will be shutdown, and warning alarm will sound. The display will show the reason for interlock.

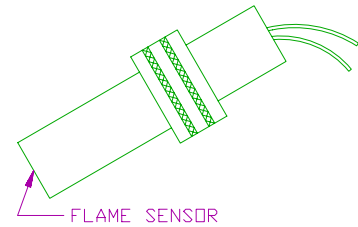

For testing, during pre-purge, take the flame eye out and point it to a flame (of a cigarette lighter for example). The boiler will continue to purge, but the pilot will not come on. After testing, do not forget to put the flame eye back to its original position and reset the XJ1 Microcomputer.

#### 4.6.7 POWER OVERLOAD

Overload or short-circuiting of the blower motor will result in boiler shutdown, activating the warning alarm, and the display will show “ALARM” and “AIR PRESS FAULT”. Some motors have an internal stator winding thermal overload feature. If thermal overload – 49F has not tripped in the boiler control panel, operation will not resume until the blower motor has cooled down.

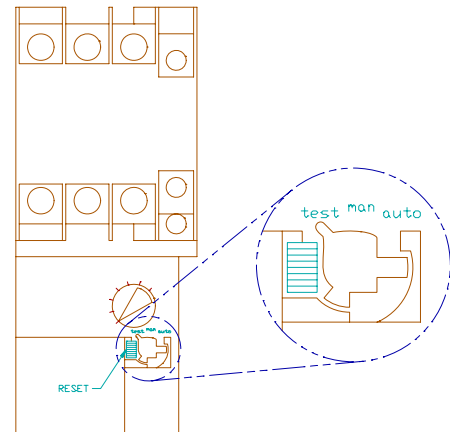

#### 4.6.8 DAMPER MICRO-SWITCH

If damper should for any reason stay in the wrong position, the micro-switch on the damper will shut down the boiler, activating the alarm and the display will also show “ALARM” and “AIR PRESS FAULT”.

#### 4.6.9 AIR PRESSURE

If the air pressure in air duct, for any reason, falls below the predetermined pressure, combustion will immediately be stopped and a warning alarm will sound. The display will also show “ALARM” and “AIR PRESS FAULT”.

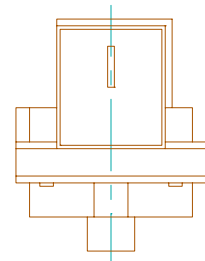

For testing, turn the setting of overload protector #88F to "TEST". During combustion, press and hold the reset button of overload protector #88F. The blower will slow down to a stop, as there will not be enough airflow and the boiler will shut down. Release the reset button, set overload protector #88F back to manual and reset the boiler.

#### 4.6.10 FUEL GAS PRESSURE

When the "COMBUSTION ON/OFF" button is pushed prior to combustion, if there is not enough gas pressure, the burner cannot ignite and the warning alarm will sound. If, during the process of boiler operation, gas pressure falls below the required range, combustion will stop, and the alarm will sound. In addition, the display will show “ALARM” and "LOW GAS PRESS" or "HIGH GAS

PRESS".

For testing the Low Gas pressure switch, close the main gas valve up-stream of the gas train during combustion. Boiler will shut off because of low gas pressure and Misfire. After resetting the XJ1 Microcomputer, the boiler will not restart because of low gas pressure until the main gas valve is opened again.

For testing the High Gas pressure switch, close the main gas burner inlet valve down-stream of the gas train during combustion. Boiler will shut off because of high gas pressure and Misfire. After resetting the XJ1 Microcomputer, the boiler will not restart because of high gas pressure until the main gas valve is opened again.

#### *4.6.11 FUEL OIL PRESSURE (STANDARD ON UL BOILER, OPTION ON OTHER)*

If, during the process of boiler operation, the oil pressure falls below the required range, combustion will stop and the alarm will sound. Also, the display will show "ALARM" and "LOW OIL PRESS".

For testing, open the circuit breaker of oil pump during combustion. The boiler will shut off because of low oil pressure and Misfire. After resetting the Flame Safeguard, the boiler still cannot restart because of low oil pressure, until the oil circuit breaker is closed again.

### **4.7 WATER TREATMENT**

**CAUTION: Check with your water treatment representative for details.**

**NOTE: Miura Boiler Co., Ltd. cannot be responsible for any problems encountered with the boiler due to unsuitable water treatment. Please contact a reliable water treatment company and follow their directions.**

#### *4.7.1 PREVENTATIVE MAINTENANCE FOR EXTENDED SHUTDOWN*

To prevent internal corrosion during periods of extended shutdown (7 days or more), the following must be done:

- a) Raise the boiler water pH level between 11-12 to reduce corrosion.
- b) Drain the water and dry the boiler completely. Add inert gas or deoxidizing agent.

Since the EX is a small water content boiler series, keeping the water in the boiler and raising the pH is the preferable preventative method. However, in places where freezing is a problem and shutdown is more than 7 days, use alternative (b) above. Contact your nearest MIURA representative or distributor for further details.

Finally, check to make sure all manual valves (water inlet, steam outlet, main & pilot gas, oil inlet...) are closed tightly and turn off the main power supply to boiler during shutdown.

#### 4.7.2 CARRYOVER

The MIURA Boiler is tested to produce steam with less than 0.25% moisture. This steam quality can be adversely affected by several factors.

1. Poor water quality: It can produce "carryover". The indications are foaming, priming and misting. Energy loss, fouling, blockage of components and corrosion will result. The EX-Series steam boiler has automatic surface blow down equipment to minimize the concentration of solids during operation. However, daily manual blow down is necessary. Follow the recommendations of a reputable water treatment company to limit conductivity.
2. Over steam demand: Exceeding the steam production rating of the boiler can overwhelm the moisture separator and allow boiler water carry over.
3. Over firing: Exceeding design heat input rate would result in steam production exceeding the capacity of the boiler and result in boiler water carry over. This condition will also shorten the life of the boiler and could cause tube damage that would not be covered by warranty.
4. Steam Demand surges: This is the normal cause of boiler water carry over for all types of boilers. This situation occurs when there is a sudden demand for steam that can be caused by types of equipment that use an on-off steam control system. This situation can be illustrated by a steam load that normally draws 25% boiler capacity and then "steps up" to 100% boiler capacity very quickly. This results in "flashing" of the water in the boiler as steam pressure drops and a momentary steam draw rate that is above nominal capacity. This "Flashing" can carry boiler water with it. This type of carry over is easily corrected by shutting the steam outlet valve and then opening it 1½ turns. This does not affect the steam production capacity of the boiler. The effect is to restrict the rate of change of the steam flow and will stop carry over caused by "Surging".
5. Water level control system faults: One example is an open circuit on the water level probes. This is extremely rare.
6. Flooded boiler: Boiler water level above normal when boiler starts. In some situations, the boiler may "siphon" water out of the feed water tank. Usually this occurs if a boiler is turned off and the isolation valves are not shut on the feed water supply.
7. Steam Pressure: Operating the boiler at less than 70 PSI steam pressure.

#### 4.7.3 BOILER MAKE UP WATER

**CAUTION: Proper water treatment MUST be used from the time the boiler is first operated. MIURA has no warranties to cover damage due to poor water treatment and failure to maintain these specifications listed below.**

#### MIURA MAKE-UP WATER MAINTENANCE CHECK

In order to keep your EX Series running in top condition, be sure to check the following daily:

- a) CHEMICAL FEED PUMP
  - i) Proper chemical feed.
  - ii) Sufficient liquids to properly dissolve chemicals.
  - iii) No air in the chemical feed pump or lines.

- b) WATER SOFTENER
- i) Boiler Make-up water is completely soft (use a test kit sensitive to less than 1.0 PPM).
  - ii) Make sure the water softener timer or softener flow meter is working everyday.
  - iii) Make sure the by-pass valve is closed and inlet and outlet valves are open.
  - iv) Make sure there is no hardening of the salt. In case of salt hardening or “bridging” break the salt into small pieces.
  - v) Make sure the polishing water softener is working properly.

### STANDARD BOILER WATER SPECIFICATIONS FOR THE EX SERIES

The chemistry values given in table below are specific guidelines established by MIURA Boiler. Analysis is to be performed by the customer or a boiler water treatment company. MIURA Boiler recommends Polymer type treatment. Phosphate type treatment results in soft sludge that is not water-soluble. Therefore, phosphate treatment results in higher solids and more frequent bottom blowoff to maintain water conductivity. Frequent bottom blowoffs will reduce the boiler system fuel to steam efficiency. Bottom blowoffs can be reduced in quantity and frequency with Polymer type treatment chemicals.

ITEM	UNITS	BOILER WATER	MAKE UP WATER
pH (at 25°C)		11.0 - 11.8	7 - 9
Hardness	CaCO <sub>3</sub>	mg/L	-0.0-
Oxygen	O <sub>2</sub>	PPM	Below 0.5 PPM or temperature above 90°C
P Alkalinity	CaCO <sub>3</sub>	mg/L	150 - 600
M Alkalinity	CaCO <sub>3</sub>	mg/L	250 - 800
Sulfites	S <sup>-</sup>	PPM	Detectable
Conductivity (at 25°C)		μS/cm	1,500 - 4,000
Chloride	Cl <sup>-</sup>	mg/L	Below 400
Silica	SiO <sub>2</sub>	mg/L	Below 250
Iron & Manganese	Fe + Mn	mg/L	Below 1.0
			Total below 0.5

**NOTE:** One of the most common causes of boiler damage is scale. Water hardness must be tested daily. The conventional method of testing water hardness is through manual testing. Results can vary due to sample and reagent amounts, personal interpretation, and lack of continuity in monitoring hardness. An optional MIURA Colormetry CMU-124H solves all these problems by offering an automatic monitoring system for sample water collection, chemical reagent injection, mixing and evaluation. With this option, MIURA boiler will also display a message “CAUTION – CHECK SOFTENER” whenever MIURA Colormetry CMU-124H detects hardness.

**NOTE:** MIURA controls the water volume of boiler by conductivity. Special care is required for conductivity of make up water that is less than 50 μS/cm. Contact MIURA for details.

## SECTION 5 MAINTENANCE

### 5.1 MAINTENANCE & CLEANING SCHEDULE

In order to protect the high efficiency and to prevent costly breakdowns of your EX Series, perform the following maintenance and cleaning.

MAINTENANCE ITEMS	EVERYDAY	EVERY 3 MONTHS	AS NEEDED	CHECK POINTS	REMARKS
Check Soft Water	☺			Is the water soft?	Scale.
Full Blowoff	☺			Refer to Blowdown and Blow-off section	Carry over, sludge, scale.
Low Water Cutoff	☺			Refer to Low Water Volume Cut-off section	For overheat protection.
Check gas Pressure	☺			Read gas pressure gauge needle for any abnormalities.	Poor combustion
Combustion Conditions	Visual	Tune up by analyzer		Check combustion: flame color and sound.	Cause of misfire.
Boiler Inside Inspection (upper and lower holes)		☺		Check for scale and sludge.	Overheating, pitting.
Check Windbox flange bolts		☺		Check for tightness.	Cause of flue gas leakage.
Check Air Duct		☺		Check air leakage.	Cause of poor combustion.
Damper setting bolts		☺		Check for tightness.	Poor combustion.
Water Volume Controller, Water Controller Rods		☺		Clean with sandpaper.	For overheat protection. Low water cutout alarms
Pilot burner condition and combustion		☺		Check electrode wear and ceramic condition.	Cause of poor ignition
Check damper motor and damper limit switch		☺		Check coupling and operation.	Poor combustion
Clean burner		Oil	Gas	Check for soot and dirt.	Poor combustion.
Check Fan Cover			☺	Clean fan cover.	Poor combustion.
Feedwater Tank			☺	Clean the inside.	Blocked feedwater.
Electrical Wiring			☺	Check for loose wires.	
Check Pressure Gauge			☺	Compare zero point to pressure gauge.	Unsuitable operation.
Strainer			Monthly	Clean the inside.	Cause of low water.
Soot blow boiler			Oil	High stack temperature.	Efficiency
Oil pump motor			☺	Check coupling wear.	

This is a basic maintenance schedule. If the fuel or water is of exceptionally poor quality, maintenance checks will naturally increase. Compare the water quality with our standards and adjust the schedule accordingly.

Electric motors are pre-lubricated at the factory and do not require additional lubrication at start up. Motors with grease fittings should only be lubricated with lithium-base grease at the time intervals given in the table below:

TYPE OF SERVICE	FREQUENCY OF GREASING
Seasonal (Motor/Boiler is idle for more than 6 months)	Yearly
Intermittently (normal daily operation of Boiler)	Semi-annually
Continuous	Quarterly

Do not over grease the bearings. Over greasing will cause increased bearing heat and can result in bearing and motor failure. Follow instructions on the motor nameplate.

**The battery in the XJ1 Microcomputer should be replaced as soon as possible if the display shows “REPLACE BATTERY”.**

It is recommended to replace the battery every 3 years.

- a) Turn off the power supply.
- b) Open CPU panel covers.
- c) Remove the battery from holder and remove the connector.
- d) Insert the connector of a new battery immediately.
- e) Fit a compatible battery into the holder and replace the panel cover.

## 5.2 SPARE PARTS

After the end of the parts warranty, it is not necessary to order replacement parts from MIURA. One of our design advantages is the use of non-proprietary parts. The electrical control components and assorted valves may be purchased from any industrial part supplies.

The list below is not all-inclusive and in general is more than required. If the customer does not have a stand by Boiler or is some distance away from the service representative or simply desires to maintain a more comprehensive selection of spare parts, contact MIURA for a more customized list.

The customer is reminded that standard ground shipment of a Warranty Replacement Part is at MIURA Expense. Express shipping charges will be billed to the Customer. In addition, return of the defective part to MIURA must be done at Customer expense. If a Warranty Replacement defective part is not returned to MIURA the customer will be invoiced for the replacement sent. In addition, if the defective part failure is determined to NOT be a manufacturing defect the Customer will be invoiced by MIURA.

NO	PART NAME	PART NUMBER	EX-100	EX-200	EX-300
1	Damper coupling rubber assembly	Lovejoy 5/8" x 7/16" L070	1	1	1
2	Flame eye	Honeywell C7035A1031	1	1	1
3	Floatless switch	26A1BO-03	1	1	1
		16B1A0-00-10	1	1	1
4	Relay	LY-2, CSA, 120V	1	1	1
5	Magnetic contactor for blower. Manufactured by Sprecher Quantity is one each, depending on boiler model and voltage	CA7-85-11-120			208 V
		CA7-72-11-120		208 V	230 V
		CA7-60-10-120		230 V	
		CA7-37-11-120	208 V		460 V 575 V
		CA7-30-10-120	230 V	460 V 575 V	
		CA7-23-10-120			
		CA7-16-10-120	460 V 575 V		
6	Magnetic contactor for Water pump Manufactured by Sprecher Quantity is one each depending on boiler model and voltage	CA7-30-10-120			208 V
		CA7-23-10-120			230 V
		CA7-16-10-120	208 V 230 V	208 V 230 V	460 V
		CA7-12-10-120	460 V 575 V	460 V 575 V	575 V
7	Magnetic contactor for oil pump Manufactured by Sprecher	CA7-12-10-120	1	1	1
8	Spark rod	SR100300	1	1	1
9	Level sensor *	Warrick 3H1C	1	1	1
10	Feed pump seal repair kit CR2/4/8 (CR1/3/5)	985201			1
		985167 (Seal: 96455086 & gasket: 96455090)	1	1	
11	Thermocouple	Type K ungrounded	1	1	1
12	Compression Fitting	CF 100000 (for thermocouple)	1	1	1

The above listed spare parts are not initially included with the boiler.

\* This is the longest level sensor probe. This probe may be shortened if necessary to replace probes in the LVC.

### 5.3 TROUBLESHOOTING

PROBLEM	ITEM TO CHECK	CAUSE	REMEDY
1. No light in "OPERATION" switch.	a) Main power switch on?		Turn main power breaker on
	b) Main power fuse tripped?	Short circuiting	Locate cause of short circuit and repair and replace fuse
	c) Circuit breaker broken OR wires loose?		Replace circuit breaker OR* tighten terminal wires
2. No display on panel.	a) No display inside control box?	Short circuiting OR circuit breaker tripping	Locate cause of short circuit and repair/reset circuit breaker
	b) Still display inside control box?	Loose wires OR broken display	Tighten terminal wires OR* replace display
3. The feed water pump does not work even though the pre-set water volume is not yet reached	a) Make sure water volume rods are not bent	Rod acting like ground to earth	Straighten rod
	b) Is retainer cracked?	Insulation failure	Replace
	c) Is Microcomputer broken?		Replace
	d) Is feedwater pump motor stopped by overload?	Feedwater pump motor broken	Replace
	e) Is current running through pump motor?	Wire is loose	Fasten wires securely
4. The feedwater pump runs but water is not being fed into boiler OR amount of feedwater is too small.	a) Are main feedwater valve and feedwater stopcocks open?		Open all feedwater valves completely
	b) Is there water in feedwater tank?		Add water
	c) Did you completely release air from air release valve?	Air in feedwater pump has stopped water from flowing	Release air completely
	d) Check direction of rotation of pump motor		Reverse the wires for the feedwater pump
	e) Is water strainer plugged?		Clean the strainer
	f) Is the feed water check valve working properly?	Check valve may stuck, not fully open	Replace check valve
	g) If the problem is not any of the above.	Pump capacity is too low	Change the pump
5. The feedwater pump keeps running even after pre-set liquid volume is reached.	a) Is retainer cracked?	Retainer is broken	Replace retainer
	b) Are nuts on upper part of retainer loose?	Wires not connected properly	Adjust wires and tighten properly
	c) Are liquid volume sensor rods dirty?	Dirt and scale prevent conduction	Clean with sandpaper OR other abrasive material
	d) Is Microcomputer broken?		Replace
6. Even after "OPERATION" switch turned "ON" and "COMBUSTION ON/OFF" button is pushed, boiler doesn't start.	a) No alarm and display shows "STAND-BY"?	Sufficient steam pressure	Drop steam pressure to automatically start boiler
		MI control set other boiler at higher priority	Change priority or set MI control to manual
		Low bubble rod did not detect water	Check electrode, pump...
7. Combustion will not start.	b) Alarm on? Check problem shown on display		Fix problem and reset boiler
	a) Main fuels cock open?	No fuels for combustion	Open main fuels valves
	b) Damper setting adjusted?	Insufficient air flow	Adjust to proper setting
	c) Fan cover clean?		

PROBLEM	ITEM TO CHECK	CAUSE	REMEDY	
	d) Main fuels valves open?	Loose wiring OR faulty fuels valve	Tighten wires OR replace	
	e) Spark rod working properly?	Loose wire	Tighten wires	
		Faulty cord on spark plug	Replace spark plug cord	*
		Carbon on spark rod	Clean up	
	f) Ultraviolet flame eye detecting flame?	Flame eye wire is loose OR faulty flame eye	Tighten wires OR replace	*
8. There is ignition but flame dies out.	a) Main fuels cock open?	No fuels for combustion	Open fuels cock	
	b) Incorrect fuel pressure OR damper setting?		Adjust to proper setting?	
	c) Is flame eye sensing flame?	Faulty flame eye or loose wire	Replace UV sensor or tight wire.	
9. Too much smoke from the chimney. Misfire becomes a problem.	a) Fuel pressure is too high	Too much fuels for combustion	Set accordingly	
	b) Is damper setting off OR is retainer loose?	Not enough air	Set accordingly OR replace damper motor	*
	c) Oil Nozzles	Broken or worn	Replace nozzle	
10. Steam is escaping from the safety valve.	a) Check the "High Limit" switch	Limit switch is not set properly OR is broken	Adjust the limit setting OR replace	*
	b) Is the pipe leading to the steam pressure switch plugged?		Remove and clean the pipe	
	c) Check safety valve setting	Improper setting	Replace if needed	*
11. Strange sound occurs on high fire.	a) Fuels pressure is low	Too much air	Adjust	
	b) Is the damper adjusted properly?			
12. Flames die out when going from high fire to low fire.	a) Check the damper position	Too much air	Adjust	
	b) Check the fuel pressure	Not enough fuel		
13. It cannot go from low fire to high fire	a) Check the damper position	Insufficient air	Adjust	
	b) Check the gas pressure	Insufficient gas pressure	Adjust	
	c) Check the two stage valve for high fire	Not enough gas for high fire	Replace and check electrical wiring	*
	d) Check the air duct fixture	Air leakage	Tighten OR replace	
	e) Check the steam high-low pressure setting. Is the pressure side on?	Incorrect wiring, OR it has reached current steam pressure setting		
	f) Check oil supply pressure and piping	Too much suction		
	g) FGR stack temperature or delay timer setting.	Set too high	Lower setting	
14. Blower motor running but no ignition.	a) Check air pressure switch	Incorrect setting, broken, OR loose wiring	Replace, reset, OR tighten terminal contacts	*
	b) Check blower rotation	Reversed rotation	Reverse wire	
	c) Check spark rod	Faulty	Replace	*
	d) Check flame safeguard	Test switch on Faulty	Set back to off Replace	 *

- ALWAYS contact your nearest MIURA representative.

## **5.4 FLOW CHART OF EX SEQUENCE OF OPERATION**

**BOILER START-UP**

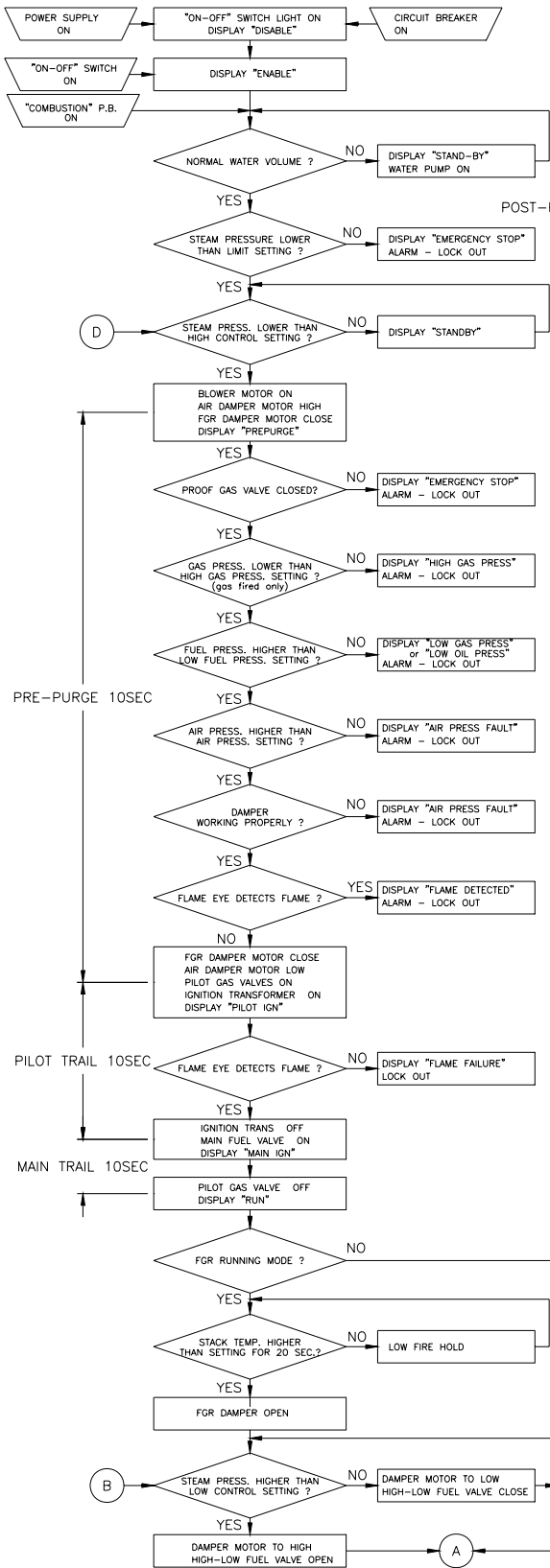

**BOILER STOPPAGE**

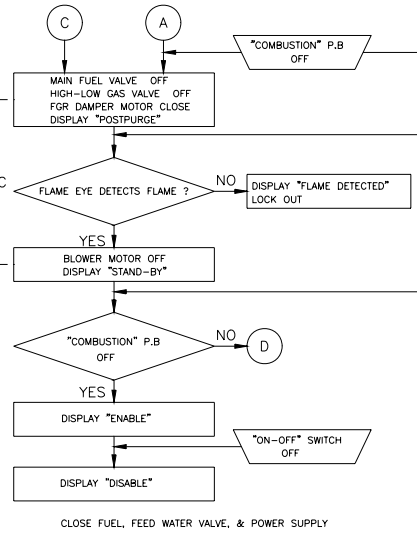

**INTER-LOCK ON COMBUSTION**

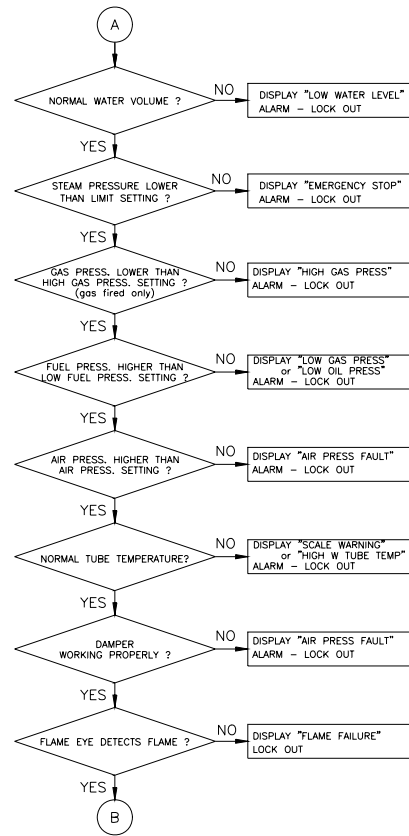

\* EX-1500 DOES NOT HAVE GAS PILOT IN OIL-FIRED.

DISTRIBUTOR INFORMATION	
NAME	
ADDRESS	
TELEPHONE	
FAX	
DATE OF INSTALLATION	
BOILER MODEL	

## MIURA BOILER OFFICES

WWW.MIURABOILER.COM

### ATLANTA:

1900 THE EXCHANGE SE, SUITE 330  
 ATLANTA, GA  
 30339-2022  
 PHONE: (770) 916-1695  
 FAX: (770) 916-1858  
[ATLANTA@MIURABOILER.COM](mailto:ATLANTA@MIURABOILER.COM)

### CHICAGO:

600 NORTHGATE PARKWAY, UNIT M  
 WHEELING, ILLINOIS  
 60090-3201  
 PHONE: (847) 465-0001  
 FAX: (847) 465-0011  
[CHICAGO@MIURABOILER.COM](mailto:CHICAGO@MIURABOILER.COM)

### LOS ANGELES:

1945 SOUTH MYRTLE AVE.  
 MONROVIA, CALIFORNIA  
 91016-4854  
 PHONE: (626) 305-6622  
 FAX: (626) 305-6624  
[LA@MIURABOILER.COM](mailto:LA@MIURABOILER.COM)

### NEW YORK:

411 Hackensack Avenue, 9<sup>th</sup> Floor  
 Hackensack, New Jersey  
 07601  
 PHONE: (201) 592-1260  
 FAX: (201) 592-1262  
[NEWJERSEY@MIURABOILER.COM](mailto:NEWJERSEY@MIURABOILER.COM)

### MIURA BOILER FACTORY:

8 COPERNICUS BLVD.,  
 BRANTFORD, ONTARIO  
 N3P 1Y4  
 PHONE: (519) 758-8111  
 FAX: (519) 758-5294  
[MIURASAL@BIS.ON.CA](mailto:MIURASAL@BIS.ON.CA)

### MISSISSAUGA:

6315 SHAWSON DRIVE, UNIT #17,  
 MISSISSAUGA, ONTARIO  
 L5T 1J2  
 PHONE: (905) 564-9199