

MIURA **EX** GAS/OIL SERIES

High Pressure Steam Boiler

NEW



**XJ1
Micro Computer
Boiler Control
System**

*The most
versatile
industrial
steam
boiler in
the world*



*The intelligent boiler
that works with you*

www.miuraboiler.com

 **MIURA**

...Setting New Standards in Boiler Technology

MIURA EX GAS/OIL SERIES

High Pressure Steam Boiler

*Revolutionary Design Produces
Revolutionary Results*

The Design:

MIURA's exclusive "low water content, watertube" design is the most versatile boiler available in the marketplace today. A once-through, forced circulation steam boiler producing steam in just 5 minutes while maintaining an 85% fuel-to-steam efficiency.

The MIURA EX SERIES design consists of rows of vertical tubes sandwiched between two annular headers. Both headers are encased in a castable refractory with only the tubes exposed to flame and/or combustion gases. The upper header is attached to the lower header only by the tubes; as the tubes expand and contract, the headers float up and down accordingly.

This 'floating header' concept, aided by forced flow, greatly reduces stress and allows for the use of cold feedwater without the fear of significant thermal shock. The 'leaky tube' problems associated with firetube and bent watertube designs have been eliminated.

Ultra Compact Design Saves Space and Costs

MIURA's EX Series boilers occupy 33% less floor space than typical firetubes, and do not require tube pull space. Compact design means much smaller radiation losses and larger fuel savings.

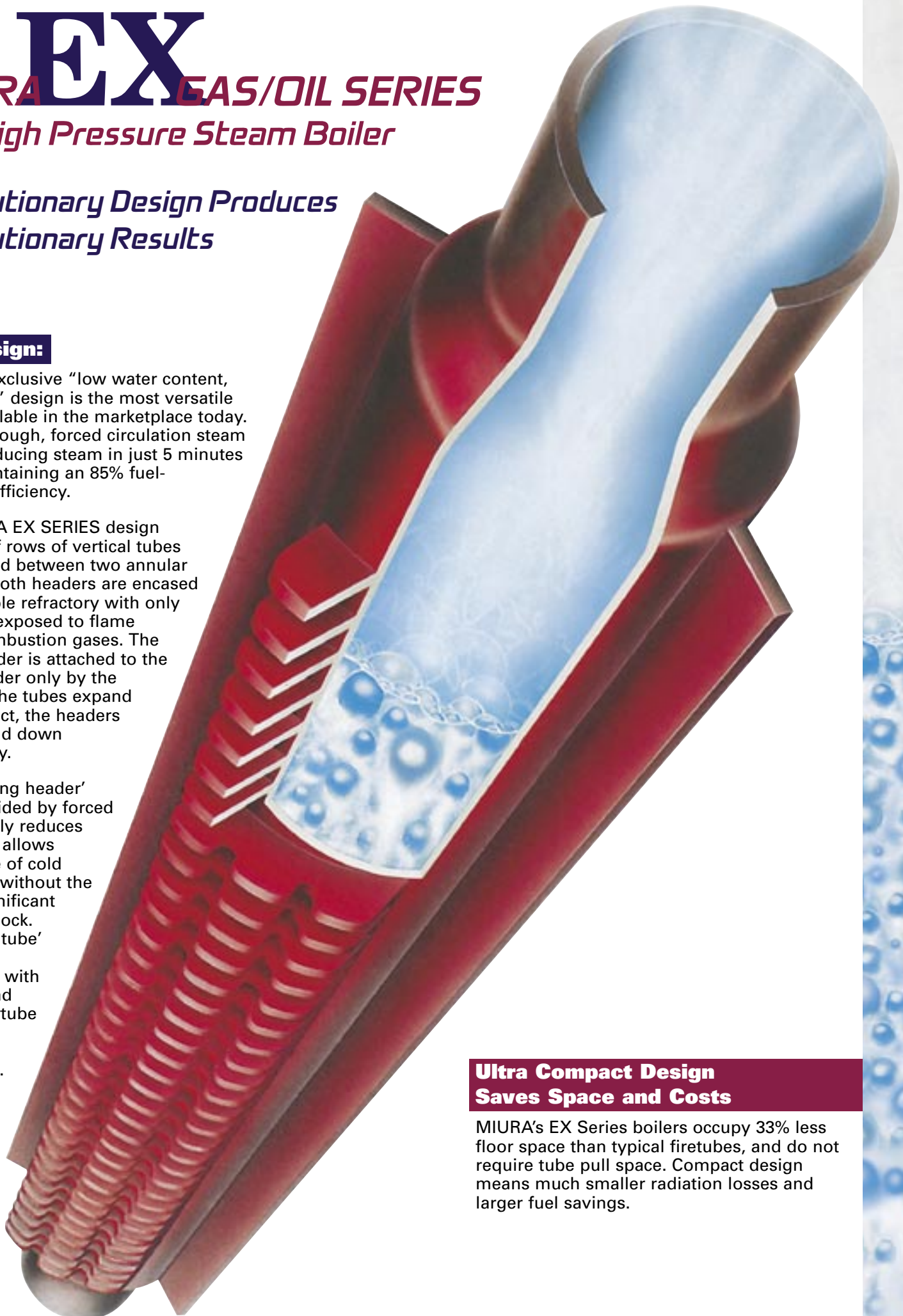

NEW

XJ1 Micro Computer Boiler Control System



**Instantly and easily
check boiler operation status**

MIURA's XJ1 Micro Computer Boiler Control System works for you and with you, identifying problems and suggesting solutions in plain, descriptive English on an easy-to-read display.

- Greater control over steam pressure settings for steadier steam pressure.
- Allows for compensated adjustment of high and low fire scale thermocouple settings.
- Allows for compensated adjustment of automatic blowdown based upon Total Dissolved Solids (TDS) and/or blowdown rates.
- Easily interfaces with the MIURA "Colormetry" unit to eliminate scale formation due to water softener failure.

Detailed Boiler Cautions

MIURA's XJ1 Control System provides detailed information on the status of critical boiler functions before problems arise; to prevent and eliminate costly boiler shut downs:

- | | |
|-----------------------------|------------------------------------|
| 1. Air Filter Clogged | 6. High Boiler Water Concentration |
| 2. High Ambient Temperature | 7. Communication Error |
| 3. Water Softener Fault | 8. Plugged Surface Blowdown Pipe |
| 4. Blowdown Timing | |
| 5. Low Battery | |

Detailed Boiler Operation Information

MIURA's XJ1 Control System utilizes ten points to measure the performance of your boiler, displayed in an easy-to-read, user-friendly format:

- | | |
|--------------------------------------|--|
| 1. Steam Pressure | 6. Flame Voltage |
| 2. Total time of Low Fire Operation | 7. Remaining time to Blowdown |
| 3. Total time of High Fire Operation | 8. Automatic Surface Blowdown Valve (On/Off) |
| 4. Scale Monitor Temperature | 9. Water Conductivity |
| 5. Overheat Thermocouple Temperature | 10. 11 point combustion sequence |

Conductivity



Scale Monitor Temperature



Boiler Water Volume



High Fire High Tube Temperature Limit



Steam Pressure Indication



Simple, intuitive programming and operation!

The XJ1 Micro Computer Control System is as simple to set up and program as it is to operate, and is fully Y2K compliant.

MIURA's training program and the intuitive, easy-to-use interface provide an intelligent boiler that works for you **and with you.**



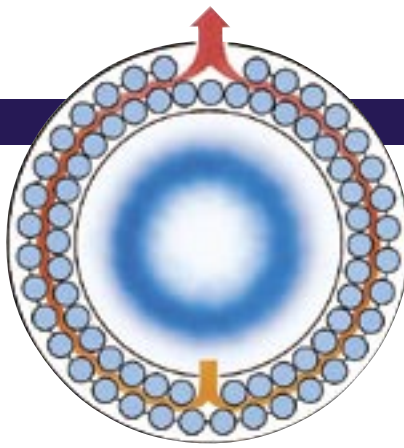

Full Steam Output Within Five Minutes

Floating headers mean fast start-up. MIURA boilers produce fast steam in 5 minutes or less from a cold start-up. Standard firetubes require from 1 to 1.5 hour start-up times. MIURA's unique design yields significant time and fuel savings.

Dry Steam

The MIURA EX design minimizes carryover and produces dry 99+% saturated steam through a 3-stage process:

- 1) *initial separation in the tubes,*
- 2) *second separation in the upper header and baffle plate,*
- 3) *final separation in the cyclone separator.*

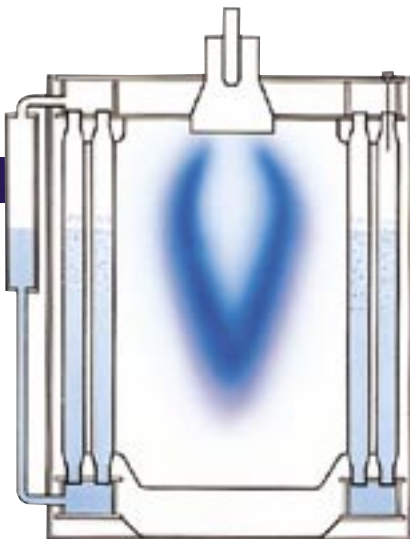
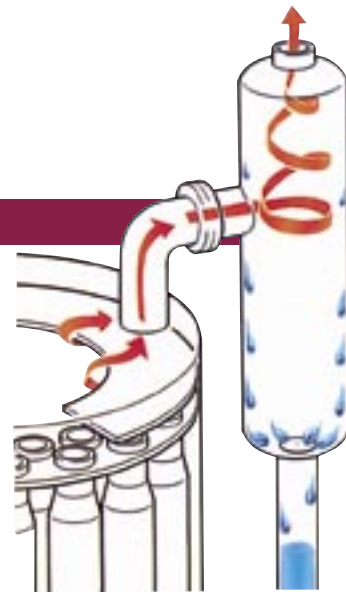

Early Warning Scale Monitors

Scale is a problem all boilers have to deal with. Scale forms when boiler feedwater is not properly treated. Advanced scale formation acts as an insulator; only an eggshell thickness of scale results in a 10% efficiency loss, higher fuel bills and possible damage to the boiler system.

As standard equipment, all MIURA EX models are equipped with thermocouples attached directly to a tube. Should scale begin to form, the MIURA boiler will alert the operator - allowing the operator to trace and repair the source of the water hardness. The boiler can then be acid rinsed to restore its original efficiencies - saving tens of thousands of dollars in wasted fuel and repair bills.

Unbeatable In-Service Efficiencies

MIURA's computer-aided design results in optimal heating surface transfer with minimal water content for fuel-to-steam efficiencies of 85%. Typical firetube designs can deliver up to 83% fuel-to-steam efficiencies. However, in actual use, MIURA averages 10 to 40% fuel savings over standard firetube designs.

How does a 2% difference in fuel-to-steam efficiencies translate into a 10 to 40% ACTUAL FUEL SAVINGS? Contact your local MIURA representative for details.

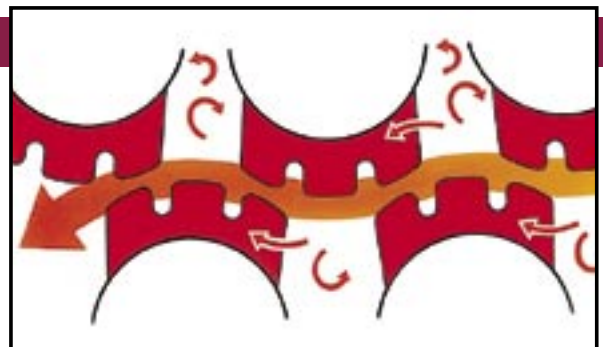

Dimensions

EX Series Gas/Oil with Economizer Dimensions

(Inches)

	A1	A2	A3	A4	B1	B2	B3	B4	H1	H2	h
EX-100 SGO	80	38	28½	9	109½	40½	12	56½	102½	69½	87
EX-200 SGO	89½	48½	32	6½	128½	51	30	65	127	78	102½
EX-250 SGO	94	50	32	6½	134	51	32	68	157	73½	119½
EX-300 SGO	94	50	32	6½	138½	51	32	72	157	81	119½

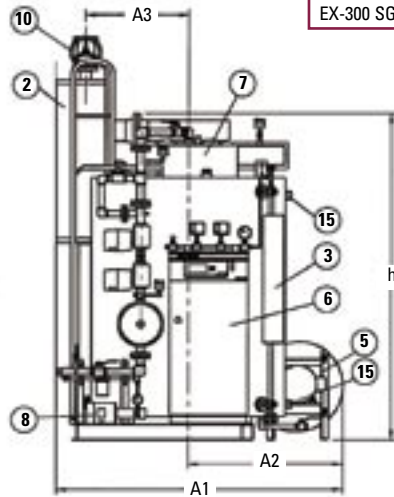

FRONT VIEW

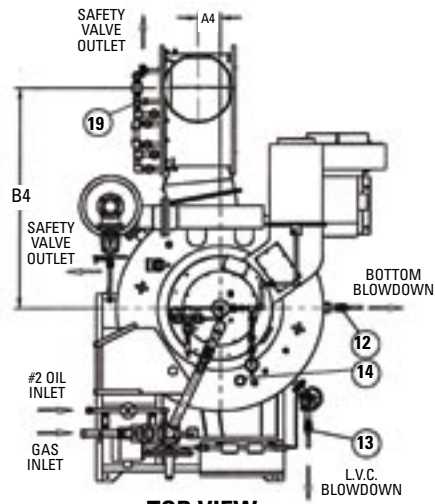

TOP VIEW

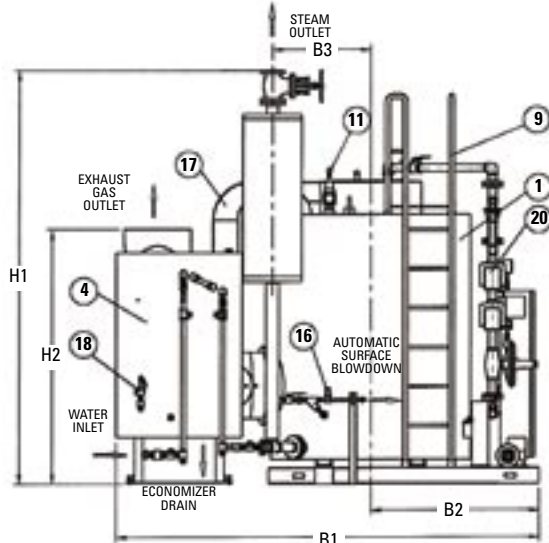

SIDE VIEW

NO.	NAME OF PART
1	BOILER VESSEL
2	STEAM SEPARATOR
3	LIQUID VOLUME CONTROLLER
4	ECONOMIZER
5	BLOWER
6	CONTROL BOX
7	WIND BOX
8	OIL PUMP (OPTION)
9	LADDER
10	STEAM OUTLET VALVE (OPTION)
11	MAIN SAFETY VALVE
12	MANUAL BLOWDOWN VALVE
13	MANUAL BLOWDOWN VALVE
14	INSPECTION HOLE (TOP)
15	INSPECTION HOLE (SIDE)
16	AUTOMATIC BLOWDOWN
17	AIR DUCT
18	ECONOMIZER SAFETY VALVE
19	FEEDWATER PIPING
20	MAIN GAS TRAIN

Schematic View (Standard)

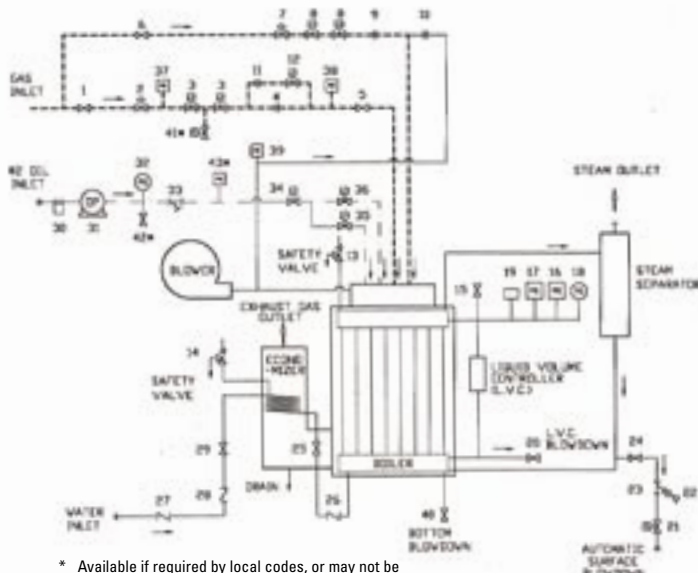

NO.	NAME OF PART	NO.	NAME OF PART
1	MAIN GAS VALVE	23	BLOWDOWN STRAINER
2	MAIN GAS REGULATOR	24	SURFACE BLOWDOWN VALVE
3	GAS CONTROL VALVE	25	WATER VALVE
4	MAIN GAS ORIFICE (LOW)	26	CHECK VALVE
5	TEST FIRING VALVE	27	CHECK VALVE
6	PILOT GAS VALVE	28	CHECK VALVE
7	PILOT GAS REGULATOR	29	VALVE
8	PILOT GAS CONTROL VALVE	30	OIL FILTER
9	PILOT GAS ORIFICE	31	OIL PUMP
10	PILOT AIR ORIFICE	32	OIL PRESSURE GAUGE
11	MAIN GAS ORIFICE (HIGH)	33	OIL STRAINER
12	HIGH-LOW CONTROL VALVE	34	OIL CONTROL VALVE
13	SAFETY VALVE	35	OIL CONTROL VALVE
14	SAFETY VALVE	36	OIL CONTROL VALVE
15	AIR VENT VALVE	37	GAS PRESSURE SWITCH
16	STEAM PRESSURE SWITCH	38	GAS PRESSURE SWITCH
17	STEAM PRESSURE SWITCH	39	AIR PRESSURE SWITCH
18	PRESSURE GAUGE	40	BOTTOM BLOWDOWN VALVE
19	PRESSURE SENSOR	41	GAS VENT VALVE*
20	L.V.C. BLOWDOWN VALVE	42	OIL VENT VALVE*
21	BLOWDOWN CONTROL VALVE	43	OIL PRESSURE SWITCH*
22	SAMPLE WATER VALVE		

* Available if required by local codes, or may not be supplied or optional according to boiler type.

** Numerous options are available upon request.

EX Series Specifications

ITEM	EX-100 SGO	EX-200 SGO	EX-250 SGO	EX-300 SGO
Utilization Horsepower	100 HP	200 HP	250 HP	300 HP
Maximum Pressure (*1)	170 PSIG MAWP, 150 PSIG Maximum Operating			
Equivalent Output (*2)	3,450 LB/HR	6,900 LB/HR	8,625 LB/HR	10,350 LB/HR
Heat Output	3,348,000 BTU/HR	6,695,000 BTU/HR	8,369,000 BTU/HR	10,050,000 BTU/HR
Efficiency (fuel to steam) (*3)	85% (80% without Economizer)			
Heating Surface Area	193 FT ²	323 FT ²	407 FT ²	390 FT ²
Operational Weight	7,250 LBS	11,500 LBS	17,500 LBS	18,000 LBS
Shipping Weight	6,750 LBS	10,650 LBS	16,600 LBS	17,100 LBS
Dimensions Given are Approximate				
Width	80 in.	89.5 in.	94 in.	94 in.
Length	109.5 in.	128.5 in.	134 in.	138.5 in.
Height	102.5 in.	127 in.	157 in.	157 in.
Combustion System	Proprietary Forced Draft, Step Fired Modulation Hi-Low-Off			
Ignition System	Electric spark ignited, Interrupted gas pilot			
Power Supply	230, 460, or 575 V, 3 PHASE, 60HZ			
Max. Electrical Consumption	13 KVA (14 for oil)	24 KVA (25 for oil)	32 KVA (34 for oil)	32 KVA (34 for oil)
Fuel Type (*4)	Natural Gas or Propane (3-5 PSIG), No. 2 oil			
Gas Consumption (*5)	3,920 SCFH	7,850 SCFH	9,810 SCFH	11,780 SCFH
No. 2 oil	27.5 GAL/Hr	55.0 GAL/Hr	68.7 GAL/Hr	82.5 GAL/Hr
Gas Supply Pressure	3-5 PSIG Natural (Gas or Propane)			
Main Steam Outlet Valve	2 in.	3 in.	4 in.	4 in.
Safety Valve Outlet	One 1 in. and One 2 in.	One 2 ½ in.		Two 2 ½ in.
Main Water Inlet	1 in.		1 ¼ in.	
Fuel Gas Inlet	2 in.		2 ½ in.	
Fuel Oil Inlet	¾ in.			
Automatic Surface Blowdown	One ¾ in.		Two ¾ in.	
Manual Blowdown	Two 1 in.		Two 1 in.	
Chimney Diameter (ID)	14 in.	20 in.	26 in.	26 in.
Flame Detector	Ultraviolet Flame Eye Sensor			
Pressure Control	Adjustable Pressure Transducer and Switch			
Liquid Volume Control	Electrolytic Conductive Type			
Overheat Protection	Low Water Cut Off & Thermocouple			

"S" - Economizer

"G" - Natural Gas or Propane Fired

"O" - #2 Oil Fired

Note:

- Optional EXH-SGO Series at 250 PSIG MAWP, 225 PSIG maximum operating.
- Equivalent output calculated from and at 212°F (100°C) feed water at 212°F (100°C) steam.
- Thermal efficiencies are based on high heating values of fuels at 68°F (20°C) feed water.
- UL and CGA/CSA approved for natural gas, propane, and No. 2 oil.
- Gas consumption based on natural gas with high heating 1004 BTU/SCF.
- All Miura steam boilers are fully packaged and test fired at factory.
- Built to meet or exceed UL & ASME standards in U.S.A.; CGA/CSA & B-51 standards in CANADA.
- Flue Gas recirculation is optional only with the Economizer.



Patented in the U.S.A.



Visit our web page at www.miuraboiler.com

MIURA Boiler Co., Ltd.

8 Copernicus Boulevard
Brantford, Ontario
N3P 1Y4 Canada

Tel: (519) 758-8111
Fax: (519) 758-5294
e-mail: canada@miuraboiler.com

MIURA Boiler Inc. (L.A.)

1945 South Myrtle Av.
Monrovia, CA
91016-4854

Tel: (626) 305-6622
Fax: (626) 305-6624
e-mail: LA@miuraboiler.com

Distributed By:

MIURA Boiler Inc. (Chicago)

600 Northgate Parkway, Suite M
Wheeling, IL
60090-3201

Tel: (847) 465-0001
Fax: (847) 465-0011
e-mail: chicago@miuraboiler.com

Printed in USA

December 02

Version 2

The descriptions and specifications are approximate.

Specifications subject to change to incorporate engineering advances. Manufacturer reserves the right to change specifications and dimensions at any time without liability for equipment previously or subsequently sold.