

# MIURA STEAM BOILER

## INSTALLATION & OPERATION MANUAL

### LX & LXL – LOW NO<sub>x</sub> SERIES

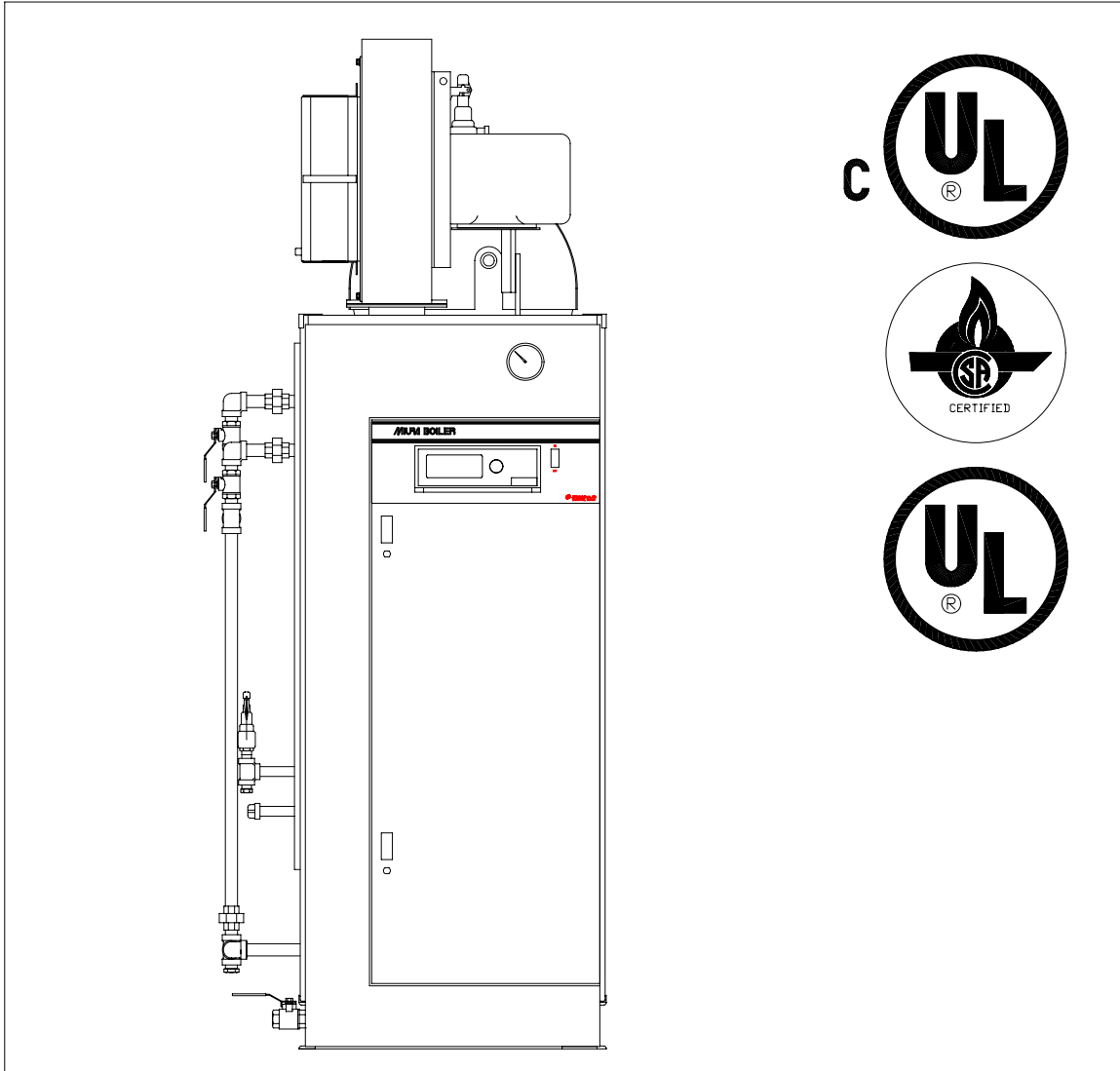

\* INFORMATION IN THIS MANUAL MAY BE CHANGED WITHOUT NOTICE.



MIURA BOILER CO., LTD.  
BRANTFORD, ONTARIO, CANADA

OWNER SHALL MAINTAIN THIS MANUAL IN LEGIBLE CONDITION FOR FUTURE REFERENCE.

Revised 02/24/06

# TABLE OF CONTENTS

<b>SECTION 1</b>	<b><i>Introduction</i></b>	<b><i>1</i></b>
1.1	Definitions and Symbols	1
1.2	Guarantee	1
1.3	Introduction	1
1.4	Features	2
1.5	Description	4
1.6	Specifications	7
<b>SECTION 2</b>	<b><i>Acts &amp; Regulations</i></b>	<b><i>15</i></b>
2.1	Acts & Regulations	18
2.2	National Regulatory Organizations	19
<b>SECTION 3</b>	<b><i>Installation</i></b>	<b><i>21</i></b>
3.1	Unloading	21
3.2	Assembling	22
3.3	Steam & Water Piping	24
3.4	Blowdown Piping	30
3.5	Fuel Piping	32
3.6	Clearances & Ventilation	35
3.7	Stacks and Breeching Installation	36
3.8	Electrical Installation	38
<b>SECTION 4</b>	<b><i>Operation</i></b>	<b><i>41</i></b>
4.1	Preparation Before	41
4.2	Start-up	41
4.3	Blowdown and Blow-off	42
4.4	Shutdown	43
4.5	Cautions during operation	43
4.6	Safety Attachments	44
4.7	Water Treatment	48
<b>SECTION 5</b>	<b><i>Maintenance</i></b>	<b><i>51</i></b>
5.1	Maintenance & Inspection Schedule	51
5.2	Spare parts	52
5.3	Troubleshooting	54
5.4	Flow chart of LX(L) Sequence Operation	56

# SECTION 1 INTRODUCTION

## 1.1 DEFINITIONS AND SYMBOLS

Note, Caution and Danger are used throughout this manual with the following definitions and symbols.

**NOTE:** Indicates an area or subject of special merit, emphasizing either the product capabilities or common errors in installation, operation or maintenance.

**CAUTION:** Indicates possible damage to equipment. It also indicates any condition or practice, which if not observed or remedied could result in damage or destruction of equipment.

**DANGER:** Indicates any condition or practice, which if not observed, could result in personal injury or possible death.

## 1.2 GUARANTEE

- Refer to warranty documents for specific details.
- SIX-MONTH labor warranty from boiler start up may be available, contact Local Sales and Service representatives for details. This labor warranty covers routine inspection and repairs at the job site. Travel and lodging expenses are not covered except within local representative service area.
- ONE YEAR Standard warranty for parts from boiler commissioning date or 18 months from shipping date whichever occurs first. Express shipping cost for overnight or next day delivery of parts is not included. Damage to the boiler or parts of the boiler after leaving the factory are not covered. Parts replaced under this warranty must be returned to MIURA. If the failed part is not returned, the customer will be charged for the new item.
- SEVEN-YEAR limited factory warranty on pressure vessel against material or workmanship defects.

## 1.3 INTRODUCTION

Miura Boiler Co., Ltd. began North American activities in 1988, when the manufacturing plant in Brantford, Ontario, was established. Their engineering department developed procedures to meet ASME codes and listing approval from UL, CSA. The United States corporate sales office, Miura Boiler, Inc., was established and has developed relationships with national, state and city inspectors and agencies.

The North American network consists of branches in Chicago, Los Angeles, New York, Atlanta and Ontario. The parent Company, Miura Boiler Ltd. in Japan, is the leading manufacturer of boilers and other thermal equipment in the Pacific Rim holding more than 55% of the market. With factories in five countries, production now exceeds 14,000 units per year.

As a result of design necessities in Japan, such as limited space and total dependence on foreign energy, the MIURA STEAM BOILER has been engineered as a highly efficient, vertical water tube, once-through, forced-flow design. The MIURA Boiler features a compact unit with a low-water content and is designed to run with a minimum amount of maintenance with simple push-button controls. Operation is quiet, radiant heat losses are minimal, and steam quality is second to none. Miura Boilers are often installed in a multiple boiler network. MIURA Boilers, along with the patented MIURA Multiple Installation panel, allows appropriate horsepower to be brought on and off line quickly to meet sophisticated production needs with maximum fuel economy. The 40-year, field proven 'Miura Advantage' is the ability to reach full output steam from cold start in less than 5 minutes using the least amount of energy and having the lowest environmental impact. The high efficiency Miura Boiler has won numerous awards from Engineering Societies and Gas Associations because it is a compact, safe, cost-effective boiler.

## 1.4 FEATURES

The MIURA BOILER is a once through, forced flow, low water content, water tube design, which provides full output within 5 minutes. Miura Boiler is designed to run with a minimum amount of maintenance with simple, push-button controls. With the patented Miura XJ1 computer controller, Miura can monitor detail boiler operation from our offices and provide fast, accurate data. In addition, it is a compact, safe, cost saving boiler. Such features contribute to the success of the Miura boiler obtaining more than 50% of the market share in Japan, Korea and Taiwan.

Miura Boiler Co., Ltd. developed the new Low NO<sub>x</sub> Boiler by using the most advanced technical methods. The flat shaped burner and the rectangular shaped boiler vessel are uniquely designed for the LX.

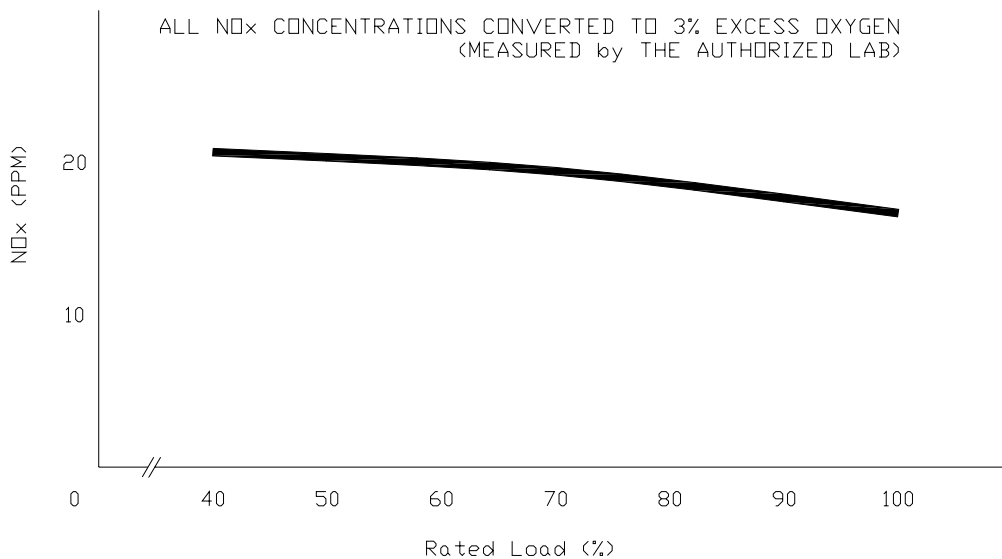

**NO<sub>x</sub> TEST DATA**

It is known that the temperature of the combustion flame should be less than 3,272°F (1,800°C) to prevent NO<sub>x</sub> generation. Generally, the combustion flame will have some high temperature areas generating NO<sub>x</sub>. Miura engineers have calculated the temperature distribution in the combustion and heat exchanging areas. From theoretical analysis and rigorous testing the designed temperature distribution is homogeneously less than 3,272°F (1,800°C). The burner surface is made as large as possible and the furnace volume as small as possible, to optimise the combustion process. As a result, the LX and LXL have NO<sub>x</sub> emissions of less than 20 PPM at 3% converted O<sub>2</sub> based on Natural Gas combustion.

The LX boiler has a very compact design. The LX fits through a standard door opening, thereby eliminating the need to destroy any standard doors or knock down any walls during installation.

The completely packaged LX has the following items as standard equipment:

- Boiler design is UL, c-UL and CSA/CGA approved and labelled (IRI and/or FM available)
- High-Low Gas pressure switches
- Low Air pressure switch
- Control Steam Pressure transducer with backup control steam pressure switch
- High Steam limit pressure switch with manual reset
- ASME steam safety relief valve for boiler (option for LXL) and optional economizer (“S” series only)
- Main gas line & Pilot line regulator
- Dual pilot gas solenoid valves
- Dual main gas fluid actuator valves and plugged leak test port (vent valve available)
- Forced draft blower and motor
- Completely enclosed, heavy gauge casing
- ASME stamped Pressure Vessel with internal Inspection ports
- Two independent Low-water fuel cut-off, one with manual reset
- Digital display steam pressure with back up pressure gauge
- Thermocouple on water tubes to prevent over heat due to low water condition or scale build up
- Water volume control
- Intermittent Automatic Blow-down system with strainer and manual shut off valve
- External separator
- Blower cover dust warning
- MIURA XJ1 Microprocessor Boiler Control with friendly digital display
- Communication interface capability
- Display of hours of operation and record of five most recent faults
- Remote monitoring of boiler performance and troubleshooting by modem link with Miura factory is available

## 1.5 DESCRIPTION

The following answers frequently asked questions through a general overview of the design and operational characteristics of Miura Boilers.

The Miura boiler design consists of straight water tubes between upper and lower headers. Both headers are encased in a castable refractory leaving only the tubes exposed to combustion gases. There is very little water and consequently very little energy stored in the steam boiler. Water volume is exclusively in the tubes with only incidental bubbling in the upper header. Therefore, the design has no natural circulation such as a riser, down comer effect common to natural circulation boilers.

Water is forced into the bottom header and tubes by means of a feed water pump. The water is flashed into steam in the tubes, forming a dynamic bubbling system that cools the tubes. This bubbling action may be best described as a "steam gradient," with more steam at the top of the tubes than at the bottom. Steam is accumulated in the upper header with a final separation in the external separator. Condensate dropped by the external separator is fed back into the lower header.

Because of the steam gradient, there is no defined steam/water level and thus no sight glass. Special modifications are incorporated into the boiler construction and safety system to accommodate this.

First, the water control system relies on electrical conductance system; when water contacts a probe, a circuit is formed. Three probes control the boiler feed with the short probe for low-fire, the medium length probe for high-fire and the long probe as low water cutout. This safety can be confusing for the inspector who encounters the Miura steam generator in the field for the first time, because a water column typically equals a "fixed water level". This is not true however for the Miura steam boiler because of the low water content and the fierce boiling action of the steam gradient. This dynamic system is controlled only by a special modification of the water column to create an artificial level. The flanged pipe leading from the boiler body runs through the column with three holes drilled in the pipe to create an orifice effect. Yet even with this orifice effect, the artificial "level" oscillates - especially with load swings on the system. This oscillation is desired and is directly proportional to the volume of water in the boiler tubes.

Secondly, the water volume control relies on electrical resistance and the bubbling action is what cools the tubes. As the volume of water in the steam boiler is consumed, there is less bubbling at the top of the tubes, increasing the amount of electrical resistance. Should the water volume ever become so low as to lose effective contact with the low water cutout probe, the boiler will shut down. On some model, an extra probe will activate the feed water pump until the bubble re-establishes effective contact with the probe.

Thirdly, thermocouples are attached directly to the tubes. The thermocouples measure the temperature of the tube and will shut the boiler down if a low water volume condition is detected due to insufficient bubbling, dry fire or if scale build-up is detected. Scale formation is monitored directly by the rise in tube surface temperature because of lower heat transfer rates.

This temperature sensing method can detect a formation of scale of less than  $\frac{1}{64}$ " and will shut down the boiler. The early detection of scale formation is an important factor in maintaining a high efficiency boiler. According to the US National Bureau of standards,  $\frac{1}{4}$ " of scale build up on heating units requires up to 55% more energy to attain the same temperature. Other methods of detecting scale, such as a pressure gauge on the discharge of the feed water pump, are much less sensitive.

The boiler will not operate should any of these low water safeties fail. Only through tampering could the boiler operate without these safeties and develop a dry fire condition. Even in the unlikely event this condition should ever be created, by the time the tubes superheat enough to destroy the tensile strength of the metal, the amount of energy contained in the remaining water is so small that the possibility of a pressure explosion is negligible.

The Miura Steam boiler design has been used for more than forty years with over 200,000 units presently in operation worldwide. There is no record of ANY pressure vessel explosion.

Steam is produced within five minutes from cold start-up and selected tubes can be visually inspected through two-inch openings located on the top and bottom headers. A complete inspection is typically accomplished in a thirty-minute period.

All Miura steam boilers are annotated as a forced flow steam generator (with no fixed steam or water level) on the pressure vessel's P-3 form and registered with the National Board. The complete packaged steam boiler is listed with UL and CSA/CGA as a standard and can be built to IRI, FM and/or ASME-CSD1 at customer request.

Please note that all flanges used on all boilers are class 150# (300# for LXH) and comply with ASME/ANSI standard B16.5. The 150# stamping refers to a standard classification, not Maximum Allowable Working Pressure (MAWP). As specified in Table A-361 of ASME codes, Section I, 1998 edition, the MAWP for 150# flanges is 205 PSIG for saturated steam service and 170 PSIG for Boiler Feed and Blow-off line service. This specification matches the 170 PSI MAWP rating of the LX boiler.

**CAUTION: All steam systems require continuous proper water treatment. This treatment is mandatory from the time your MIURA BOILER is installed. Failure to follow the recommended water treatment and maintenance procedures could shorten the life (as well as the efficiency) of your boiler and could affect the warranty.**

\* THIS DRAWING IS FOR ILLUSTRATION PURPOSES ONLY.  
VARIATIONS MAY APPLY FOR VARIOUS MODELS.

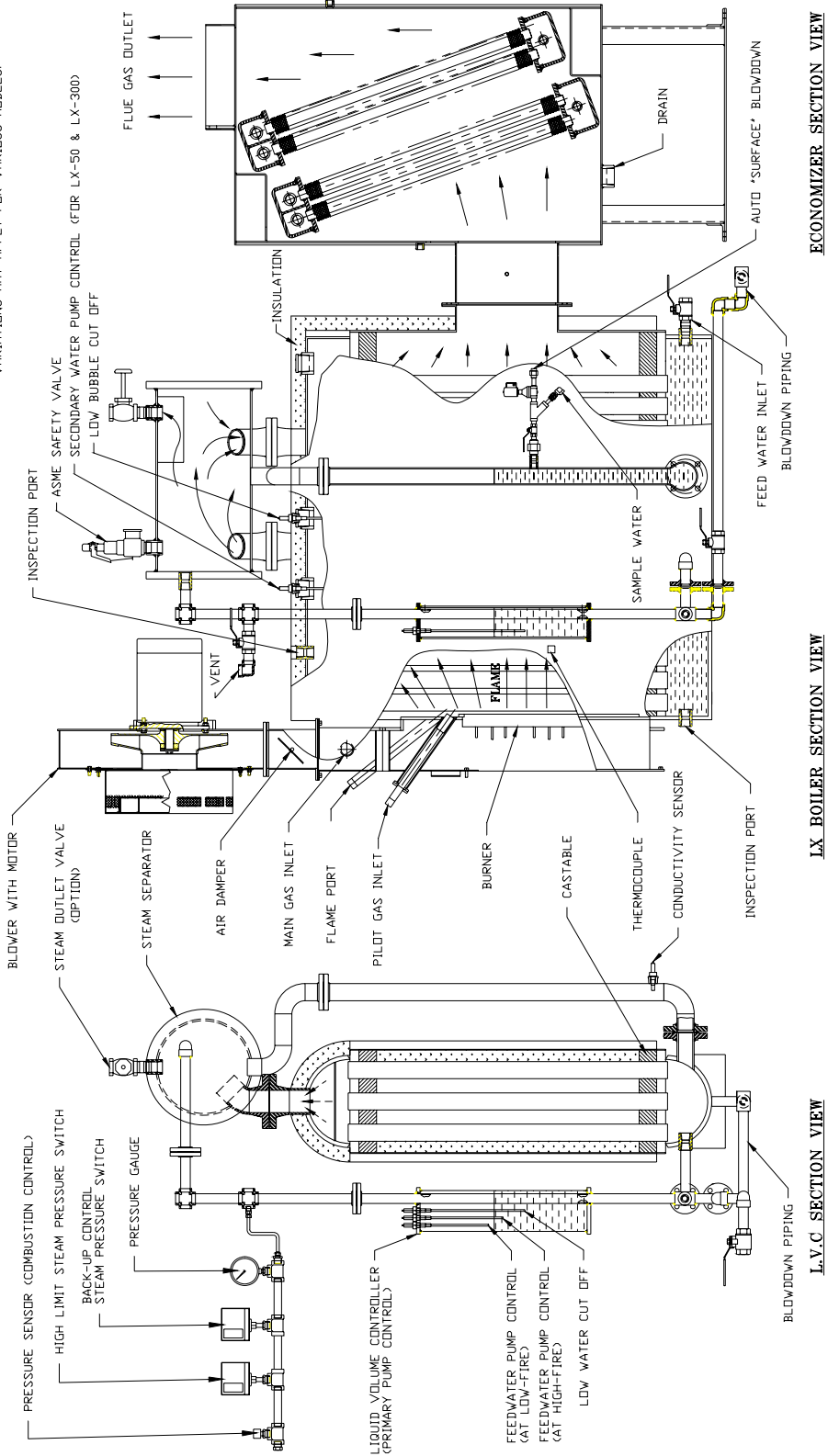

**LX BOILER SECTION VIEW**

**ECONOMIZER SECTION VIEW**

**LX BOILER SECTION VIEW**

**L.V.C SECTION VIEW**

© MIURA BOILER CO., LTD.

## 1.6 SPECIFICATIONS

### 1.6.1 SPECIFICATIONS FOR LX-50

ITEM	UNITS	LX-50 G	LX-50 SG
Boiler Type	Multiple water tube, once through, forced flow, steam boiler		
Boiler Horsepower Rating	BHP	50	
Maximum Pressure	PSIG (Kg/cm <sup>2</sup> )	170 (11.95) design / 150 (10.55) operating	
Equivalent Output	Lb/Hr (Kg/Hr)	1,725 (782)	
Heat Output	Btu/Hr	1,674,000 (421,800)	
Heat Input	(KCal/Hr)	2,066,000 (520,700)	1,969,000 (496,200)
Efficiency (fuel to steam)	%	81	85
Boiler Heating Surface Area	Ft <sup>2</sup> (m <sup>2</sup> )	177 (16.4)	
Operational Weight	Lb (Kg)	3,500 (1,600)	4,070 (1,850)
Shipping Weight	Lb (Kg)	3,150 (1,430)	3,840 (1,740)
Combustion Control	3 position step burner HIGH-LOW-OFF		
Combustion System	Forced draft, pre-mixed burner		
Ignition System	Electric spark ignited interrupted gas pilot		
Power Supply	575, 460, or 240V, 3 phase, 60 Hz		
Max. Electrical Consumption	KVA	6.8	
Blower Motor Output	HP (KW)	3.0 (2.25)	
Fuel Consumption	SCFH (Nm <sup>3</sup> /Hr)	2,058 (55.1)	1,960 (52.5)
Fuel Supply Pressure	PSIG	3 - 5 (natural gas or propane)	
Flue Gas Volume (Wet)	SCFH (Nm <sup>3</sup> /Hr)	27,600 (741)	26,300 (706)
Flue Gas Volume (Dry)		23,600 (631)	22,400 (600)
Flue Gas Velocity	Ft/s (m/s)	17.5 (5.3)	13.1 (4.0)
Flue Gas Temperature	°F (°C)	450 (230)	270 (130)
Main Steam Outlet	Inches	2" NPT	
Safety Valve Outlet		1½" for boiler and optional 1¼" for economizer	
Feedwater Inlet		¾" NPT	
Fuel Gas Inlet		1½" NPT	
Automatic "Surface" Blowdown		⅜" NPT	
Boiler & LVC Drain		2 x 1" NPT	
Chimney Diameter		12" ID	
Flame Detector		Ultraviolet flame eye sensor	
Overheat Protection	High tube temperature & Low water cut-off.		

#### NOTE:

- i. Equivalent output is calculated from and at 212°F (100°C) feedwater to 212°F steam.
- ii. Gas consumption based on Natural Gas with High heating value 1,004 Btu/SCF.
- iii. Thermal efficiencies are based on high heating values of fuels.
- iv. Flue gas temperature & velocity are calculated for Natural Gas with 68°F (20°C) feedwater.
- v. Boiler Safety valve Outlet size may increase if set below 170 PSIG.

## 1.6.2 SPECIFICATIONS FOR LXL-50

ITEM	UNITS	LXL-50 G	LXL-50 SG
Boiler Type	Multiple water tube, once through, forced flow, steam boiler		
Boiler Horsepower Rating	BHP	50	
Maximum Pressure	PSIG (Kg/cm <sup>2</sup> )	170 (11.95) design / 15 (1.05) operating	
Equivalent Output	Lb/Hr (Kg/Hr)	1,725 (782)	
Heat Output	Btu/Hr (KCal/Hr)	1,674,000 (421,800)	
Heat Input		2,066,000 (520,700)	1,969,000 (496,200)
Efficiency (fuel to steam)	%	81	85
Boiler Heating Surface Area	Ft <sup>2</sup> (m <sup>2</sup> )	177 (16.4)	
Operational Weight	Lb (Kg)	3,500 (1,600)	4,070 (1,850)
Shipping Weight	Lb (Kg)	3,150 (1,430)	3,840 (1,740)
Combustion Control	3 position step burner HIGH-LOW-OFF		
Combustion System	Forced draft, pre-mixed burner		
Ignition System	Electric spark ignited interrupted gas pilot		
Power Supply	575, 460, or 240V, 3 phase, 60 Hz		
Max. Electrical Consumption	KVA	5.0	
Blower Motor Output	HP (KW)	3.0 (2.25)	
Fuel Consumption	SCFH (Nm <sup>3</sup> /Hr)	2,058 (55.1)	1,960 (52.5)
Fuel Supply Pressure	PSIG	3 - 5 (natural gas or propane)	
Flue Gas Volume (Wet)	SCFH (Nm <sup>3</sup> /Hr)	27,600 (741)	26,300 (706)
Flue Gas Volume (Dry)		23,600 (631)	22,400 (600)
Flue Gas Velocity	Ft/s (m/s)	17.5 (5.3)	13.1 (4.0)
Flue Gas Temperature	°F (°C)	450 (230)	270 (130)
Main Steam Outlet	Inches	4" FLG	
Safety Valve Outlet		2½" for boiler and optional 1¼" for economizer	
Feedwater Inlet		¾" NPT	
Fuel Gas Inlet		1½" NPT	
Automatic "Surface" Blowdown		⅜" NPT	
Boiler & LVC Drain		2 x 1" NPT	
Chimney Diameter		12" ID	
Flame Detector		Ultraviolet flame eye sensor	
Overheat Protection	High tube temperature & Low water cut-off.		

### NOTE:

- i. Equivalent output is calculated from and at 212°F (100°C) feedwater to 212°F steam.
- ii. Gas consumption based on Natural Gas with High heating value 1,004 Btu/SCF.
- iii. Thermal efficiencies are based on high heating values of fuels.
- iv. Flue gas temperature & velocity are calculated for Natural Gas with 68°F (20°C) feedwater.

### 1.6.3 SPECIFICATIONS FOR LX-100

ITEM	UNITS	LX-100 G	LX-100 SG
Boiler Type	Multiple water tube, once through, forced flow, steam boiler		
Boiler Horsepower Rating	BHP	100	
Maximum Pressure	PSIG (Kg/cm <sup>2</sup> )	170 (11.95) design / 150 (10.55) operating	
Equivalent Output	Lb/Hr (Kg/Hr)	3,450 (1,565)	
Heat Output	Btu/Hr (KCal/Hr)	3,348,000 (843,600)	
Heat Input		4,133,000 (1,041,000)	3,938,000 (992,400)
Efficiency (fuel to steam)	%	81	85
Boiler Heating Surface Area	Ft <sup>2</sup> (m <sup>2</sup> )	248 (23)	
Operational Weight	Lb (Kg)	5,300 (2,400)	6,070 (2,750)
Shipping Weight	Lb (Kg)	4,910 (2,230)	5,470 (2,480)
Combustion Control	3 position step burner HIGH-LOW-OFF		
Combustion System	Forced draft, pre-mixed burner		
Ignition System	Electric spark ignited interrupted gas pilot		
Power Supply	575, 460, or 240V, 3 phase, 60 Hz		
Max. Electrical Consumption	KVA	13.4	
Blower Motor Output	HP (KW)	10 (7.5)	
Fuel Consumption	SCFH (Nm <sup>3</sup> /Hr)	4,120 (110.4)	3,920 (105.5)
Fuel Supply Pressure	PSIG	3 - 5 (natural gas or propane)	
Flue Gas Volume (Wet)	SCFH (Nm <sup>3</sup> /Hr)	55,200 (1,479)	52,500 (1,407)
Flue Gas Volume (Dry)		47,200 (1,265)	44,900 (1,203)
Flue Gas Velocity	Ft/s (m/s)	25.6 (7.8)	19.1 (5.8)
Flue Gas Temperature	°F (°C)	450 (230)	270 (130)
Main Steam Outlet	Inches	2" NPT	
Safety Valve Outlet		2" for boiler and optional 1¼" for economizer	
Feedwater Inlet		1" NPT	
Fuel Gas Inlet		2" NPT	
Automatic "Surface" Blowdown		¾" NPT	
Boiler & LVC Drain		2 x 1" NPT	
Chimney Diameter		14" ID	
Flame Detector	Ultraviolet flame eye sensor		
Overheat Protection	High tube temperature & Low water cut-off.		

**NOTE:**

- i. Equivalent output is calculated from and at 212°F (100°C) feedwater to 212°F steam.
- ii. Gas consumption based on Natural Gas with High heating value 1,004 Btu/SCF.
- iii. Thermal efficiencies are based on high heating values of fuels.
- iv. Flue gas temperature & velocity are calculated for Natural Gas with 68°F (20°C) feedwater.
- v. Boiler Safety valve Outlet size may increase if set below 170 PSIG.

1.6.4 SPECIFICATIONS FOR LXL-100

ITEM	UNITS	LXL-100 G	LXL-100 SG
Boiler Type	Multiple water tube, once through, forced flow, steam boiler		
Boiler Horsepower Rating	BHP	100	
Maximum Pressure	PSIG (Kg/cm <sup>2</sup> )	170 (11.95) design / 15 (1.05) operating	
Equivalent Output	Lb/Hr (Kg/Hr)	3,450 (1,565)	
Heat Output	Btu/Hr (KCal/Hr)	3,348,000 (843,600)	
Heat Input		4,133,000 (1,041,000)	3,938,000 (992,400)
Efficiency (fuel to steam)	%	81	85
Boiler Heating Surface Area	Ft <sup>2</sup> (m <sup>2</sup> )	248 (23)	
Operational Weight	Lb (Kg)	5,700 (2,600)	6,500 (2,950)
Shipping Weight	Lb (Kg)	5,160 (2,340)	5,900 (2,670)
Combustion Control	3 position step burner HIGH-LOW-OFF		
Combustion System	Forced draft, pre-mixed burner		
Ignition System	Electric spark ignited interrupted gas pilot		
Power Supply	575, 460, or 240V, 3 phase, 60 Hz		
Max. Electrical Consumption	KVA	11.6	
Blower Motor Output	HP (KW)	10 (7.5)	
Fuel Consumption	SCFH (Nm <sup>3</sup> /Hr)	4,120 (110.4)	3,920 (105.5)
Fuel Supply Pressure	PSIG	3 - 5 (natural gas or propane)	
Flue Gas Volume (Wet)	SCFH (Nm <sup>3</sup> /Hr)	55,200 (1,479)	52,500 (1,407)
Flue Gas Volume (Dry)		47,200 (1,265)	44,900 (1,203)
Flue Gas Velocity	Ft/s (m/s)	25.6 (7.8)	19.1 (5.8)
Flue Gas Temperature	°F (°C)	450 (230)	270 (130)
Main Steam Outlet	Inches	6" FLG	
Safety Valve Outlet		2 x 2½" for boiler and optional 1¼" for economizer	
Feedwater Inlet		1" NPT	
Fuel Gas Inlet		2" NPT	
Automatic "Surface" Blowdown		¾" NPT	
Boiler & LVC Drain		2 x 1" NPT	
Chimney Diameter		14" ID	
Flame Detector		Ultraviolet flame eye sensor	
Overheat Protection	High tube temperature & Low water cut-off.		

**NOTE:**

- i. Equivalent output is calculated from and at 212°F (100°C) feedwater to 212°F steam.
- ii. Gas consumption based on Natural Gas with High heating value 1,004 Btu/SCF.
- iii. Thermal efficiencies are based on high heating values of fuels.
- iv. Flue gas temperature & velocity are calculated for Natural Gas with 68°F (20°C) feedwater.

1.6.5 SPECIFICATIONS FOR LX-150

ITEM	UNITS	LX-150 G	LX-150 SG
Boiler Type	Multiple water tube, once through, forced flow, steam boiler		
Boiler Horsepower Rating	BHP	150	
Maximum Pressure	PSIG (Kg/cm <sup>2</sup> )	170 (11.95) design / 150 (10.55) operating	
Equivalent Output	Lb/Hr (Kg/Hr)	5,175 (2,347)	
Heat Output	Btu/Hr (KCal/Hr)	5,022,000 (1,265,000)	
Heat Input		6,277,000 (1,582,000)	5,908,000 (1,489,000)
Efficiency (fuel to steam)	%	80	85
Boiler Heating Surface Area	Ft <sup>2</sup> (m <sup>2</sup> )	397 (36.9)	
Operational Weight	Lb (Kg)	7,500 (3,400)	9,600 (4,360)
Shipping Weight	Lb (Kg)	6,850 (3,110)	8,950 (4,060)
Combustion Control	3 position step burner HIGH-LOW-OFF		
Combustion System	Forced draft, pre-mixed burner		
Ignition System	Electric spark ignited interrupted gas pilot		
Power Supply	575, 460, or 240V, 3 phase, 60 Hz		
Max. Electrical Consumption	KVA	20.0	
Blower Motor Output	HP	15	
Fuel Consumption	SCFH (Nm <sup>3</sup> /Hr)	6,250 (167.4)	5,880 (158.3)
Fuel Supply Pressure	PSIG	3 - 5 (natural gas or propane)	
Flue Gas Volume (Wet)	SCFH (Nm <sup>3</sup> /Hr)	83,700 (2,242)	78,800 (2,111)
Flue Gas Volume (Dry)		71,500 (1,916)	67,300 (1,803)
Flue Gas Velocity	Ft/s (m/s)	38.9 (11.9)	28.7 (8.7)
Flue Gas Temperature	°F (°C)	470 (240)	270 (130)
Main Steam Outlet	Inches	3" FLG	
Safety Valve Outlet		2½" for boiler and optional 1¼" for economizer	
Feedwater Inlet		1" NPT	
Fuel Gas Inlet		2" NPT	
Automatic "Surface" Blowdown		¾" NPT	
Boiler & LVC Drain		2 x 1" NPT	
Chimney Diameter		14" ID	
Flame Detector		Ultraviolet flame eye sensor	
Overheat Protection	High tube temperature & Low water cut-off.		

**NOTE:**

- i. Equivalent output is calculated from and at 212°F (100°C) feedwater to 212°F steam.
- ii. Gas consumption based on Natural Gas with High heating value 1,004 Btu/SCF.
- iii. Thermal efficiencies are based on high heating values of fuels.
- iv. Flue gas temperature & velocity are calculated for Natural Gas with 68°F (20°C) feedwater.
- v. Boiler Safety valve Outlet size may increase if set below 170 PSIG.

1.6.6 SPECIFICATIONS FOR LXL-150

ITEM	UNITS	LXL-150 G	LXL-150 SG
Boiler Type	Multiple water tube, once through, forced flow, steam boiler		
Boiler Horsepower Rating	BHP	150	
Maximum Pressure	PSIG (Kg/cm <sup>2</sup> )	170 (11.95) design / 15 (1.05) operating	
Equivalent Output	Lb/Hr (Kg/Hr)	5,175 (2,347)	
Heat Output	Btu/Hr	5,022,000 (1,265,000)	
Heat Input	(KCal/Hr)	6,199,000 (1,562,000)	5,908,000 (1,489,000)
Efficiency (fuel to steam)	%	81	85
Boiler Heating Surface Area	Ft <sup>2</sup> (m <sup>2</sup> )	496 (46.1)	
Operational Weight	Lb (Kg)	10,700 (4,860)	12,340 (5,600)
Shipping Weight	Lb (Kg)	9,800 (4,500)	11,500 (5,200)
Combustion Control	3 position step burner HIGH-LOW-OFF		
Combustion System	Forced draft, pre-mixed burner		
Ignition System	Electric spark ignited interrupted gas pilot		
Power Supply	575, 460, or 240V, 3 phase, 60 Hz		
Max. Electrical Consumption	KVA	17.0	
Blower Motor Output	HP	15	
Fuel Consumption	SCFH (Nm <sup>3</sup> /Hr)	6,250 (167.4)	5,880 (158.3)
Fuel Supply Pressure	PSIG	3 - 5 (natural gas or propane)	
Flue Gas Volume (Wet)	SCFH (Nm <sup>3</sup> /Hr)	83,700 (2,242)	78,800 (2,111)
Flue Gas Volume (Dry)		71,500 (1,916)	67,300 (1,803)
Flue Gas Velocity	Ft/s (m/s)	38.9 (11.9)	28.7 (8.7)
Flue Gas Temperature	°F (°C)	470 (240)	270 (130)
Main Steam Outlet	Inches	8" FLG	
Safety Valve Outlet		2 x 4" for boiler and optional 1¼" for economizer	
Feedwater Inlet		1" NPT	
Fuel Gas Inlet		2" NPT	
Automatic "Surface" Blowdown		¾" NPT	
Boiler & LVC Drain		2 x 1" NPT	
Chimney Diameter		20" ID	
Flame Detector		Ultraviolet flame eye sensor	
Overheat Protection	High tube temperature & Low water cut-off.		

**NOTE:**

- i. Equivalent output is calculated from and at 212°F (100°C) feedwater to 212°F steam.
- ii. Gas consumption based on Natural Gas with High heating value 1,004 Btu/SCF.
- iii. Thermal efficiencies are based on high heating values of fuels.
- iv. Flue gas temperature & velocity are calculated for Natural Gas with 68°F (20°C) feedwater.

1.6.7 SPECIFICATIONS FOR LX-200

ITEM	UNITS	LX-200 G	LX-200 SG
Boiler Type	Multiple water tube, once through, forced flow, steam boiler		
Boiler Horsepower Rating	BHP	200	
Maximum Pressure	PSIG (Kg/cm <sup>2</sup> )	170 (11.95) design / 150 (10.55) operating	
Equivalent Output	Lb/Hr (Kg/Hr)	6,900 (3,129)	
Heat Output	Btu/Hr (KCal/Hr)	6,695,000 (1,687,000)	
Heat Input		8,369,000 (2,109,000)	7,876,000 (1,985,000)
Efficiency (fuel to steam)	%	80	85
Boiler Heating Surface Area	Ft <sup>2</sup> (m <sup>2</sup> )	397 (36.9)	
Operational Weight	Lb (Kg)	8,900 (4,040)	10,000 (4,540)
Shipping Weight	Lb (Kg)	8,200 (3,720)	9,200 (4,180)
Combustion Control	3 position step burner HIGH-LOW-OFF		
Combustion System	Forced draft, pre-mixed burner		
Ignition System	Electric spark ignited interrupted gas pilot		
Power Supply	575, 460, or 240V, 3 phase, 60 Hz		
Max. Electrical Consumption	KVA	20.0	
Blower Motor Output	HP	15	
Fuel Consumption	SCFH (Nm <sup>3</sup> /Hr)	8,340 (223.4)	7,850 (211.0)
Fuel Supply Pressure	PSIG	3 - 5 (natural gas or propane)	
Flue Gas Volume (Wet)	SCFH (Nm <sup>3</sup> /Hr)	112,000 (2,999)	105,000 (2,813)
Flue Gas Volume (Dry)		95,500 (2,559)	89,900 (2,409)
Flue Gas Velocity	Ft/s (m/s)	25.5 (7.8)	18.8 (5.7)
Flue Gas Temperature	°F (°C)	470 (240)	270 (130)
Main Steam Outlet	Inches	3" FLG	
Safety Valve Outlet		2½" for boiler and optional 1¼" for economizer	
Feedwater Inlet		1" NPT	
Fuel Gas Inlet		2" NPT	
Automatic "Surface" Blowdown		¾" NPT	
Boiler & LVC Drain		2 x 1" NPT	
Chimney Diameter		20" ID	
Flame Detector		Ultraviolet flame eye sensor	
Overheat Protection	High temperature & Low water cut-off.		

**NOTE:**

- i. Equivalent output is calculated from and at 212°F (100°C) feedwater to 212°F steam.
- ii. Gas consumption based on Natural Gas with High heating value 1,004 Btu/SCF.
- iii. Thermal efficiencies are based on high heating values of fuels.
- iv. Flue gas temperature & velocity are calculated for Natural Gas with 68°F (20°C) feedwater.
- v. Boiler Safety valve Outlet size may increase if set below 170 PSIG.

1.6.8 SPECIFICATIONS FOR LXL-200

ITEM	UNITS	LXL-200 G	LXL-200 SG
Boiler Type	Multiple water tube, once through, forced flow, steam boiler		
Boiler Horsepower Rating	BHP	200	
Maximum Pressure	PSIG (Kg/cm <sup>2</sup> )	170 (11.95) design / 15 (1.05) operating	
Equivalent Output	Lb/Hr (Kg/Hr)	6,900 (3,129)	
Heat Output	Btu/Hr	6,695,000 (1,687,000)	
Heat Input	(KCal/Hr)	8,265,000 (2,083,000)	7,876,000 (1,985,000)
Efficiency (fuel to steam)	%	81	85
Boiler Heating Surface Area	Ft <sup>2</sup> (m <sup>2</sup> )	496 (46.1)	
Operational Weight	Lb (Kg)	10,700 (4,860)	12,340 (5,600)
Shipping Weight	Lb (Kg)	9,800 (4,500)	12,200 (5,540)
Combustion Control	3 position step burner HIGH-LOW-OFF		
Combustion System	Forced draft, pre-mixed burner		
Ignition System	Electric spark ignited interrupted gas pilot		
Power Supply	575, 460, or 240V, 3 phase, 60 Hz		
Max. Electrical Consumption	KVA	17.0	
Blower Motor Output	HP	15	
Fuel Consumption	SCFH (Nm <sup>3</sup> /Hr)	8,340 (223.4)	7,850 (211.0)
Fuel Supply Pressure	PSIG	3 - 5 (natural gas or propane)	
Flue Gas Volume (Wet)	SCFH (Nm <sup>3</sup> /Hr)	112,000 (2,999)	105,000 (2,813)
Flue Gas Volume (Dry)		95,500 (2,559)	89,900 (2,409)
Flue Gas Velocity	Ft/s (m/s)	25.5 (7.8)	18.8 (5.7)
Flue Gas Temperature	°F (°C)	470 (240)	270 (130)
Main Steam Outlet	Inches	8" FLG	
Safety Valve Outlet		2 x 4" for boiler and optional 1¼" for economizer	
Feedwater Inlet		1" NPT	
Fuel Gas Inlet		2" NPT	
Automatic "Surface" Blowdown		¾" NPT	
Boiler & LVC Drain		2 x 1" NPT	
Chimney Diameter		20" ID	
Flame Detector		Ultraviolet flame eye sensor	
Overheat Protection	High temperature & Low water cut-off.		

**NOTE:**

- i. Equivalent output is calculated from and at 212°F (100°C) feedwater to 212°F steam.
- ii. Gas consumption based on Natural Gas with High heating value 1,004 Btu/SCF.
- iii. Thermal efficiencies are based on high heating values of fuels.
- iv. Flue gas temperature & velocity are calculated for Natural Gas with 68°F (20°C) feedwater.

1.6.9 SPECIFICATIONS FOR LXH-200 (SPECIAL)

ITEM	UNITS	LXH-200 SG
Boiler Type	Multiple water tube, once through, forced flow, steam boiler	
Boiler Horsepower Rating	BHP	190
Maximum Pressure	PSIG (Kg/cm <sup>2</sup> )	250 (17.6)
Equivalent Output	Lb/Hr (Kg/Hr)	6,555 (2,973)
Heat Output	Btu/Hr (KCal/Hr)	6,361,000 (1,603,000)
Heat Input		7,572,000 (1,908,000)
Efficiency (fuel to steam)	%	84
Boiler Heating Surface Area	Ft <sup>2</sup> (m <sup>2</sup> )	397 (36.9)
Operational Weight	Lb (Kg)	10,400 (4,720)
Shipping Weight	Lb (Kg)	9,600 (4,360)
Combustion Control	3 position step burner HIGH-LOW-OFF	
Combustion System	Forced draft, pre-mixed burner	
Ignition System	Electric spark ignited interrupted gas pilot	
Power Supply	575, 460, or 240V, 3 phase, 60 Hz	
Max. Electrical Consumption	KVA	25.0
Blower Motor Output	HP	15
Fuel Consumption	SCFH (Nm <sup>3</sup> /Hr)	7,570 (203)
Fuel Supply Pressure	PSIG	3 - 5 (natural gas or propane)
Flue Gas Volume (Wet)	SCFH (Nm <sup>3</sup> /Hr)	99,600 (2,714)
Flue Gas Volume (Dry)		84,800 (2,314)
Flue Gas Velocity	Ft/s (m/s)	19.3 (5.9)
Flue Gas Temperature	°F (°C)	320 (160)
Main Steam Outlet	Inches	3" FLG
Safety Valve Outlet		2½" for boiler and optional 1¼" for economizer
Feedwater Inlet		1" NPT
Fuel Gas Inlet		2" NPT
Automatic "Surface" Blowdown		¾" NPT
Boiler & LVC Drain		2 x 1" NPT
Chimney Diameter		20" ID
Flame Detector	Ultraviolet flame eye sensor	
Overheat Protection	High tube temperature & Low water cut-off.	

**NOTE:**

- i. Equivalent output is calculated from and at 212°F (100°C) feedwater to 212°F steam.
- ii. Gas consumption based on Natural Gas with High heating value 1,004 Btu/SCF.
- iii. Thermal efficiencies are based on high heating values of fuels.
- iv. Flue gas temperature & velocity are calculated for Natural Gas with 68°F (20°C) feedwater.
- v. Boiler Safety valve Outlet size may increase if set below 250 PSIG.

1.6.10 SPECIFICATIONS FOR LX-300

ITEM	UNITS	LX-300 SG
Boiler Type	Multiple water tube, once through, forced flow, steam boiler	
Boiler Horsepower Rating	BHP	300
Maximum Pressure	PSIG (Kg/cm <sup>2</sup> )	170 (11.95) design / 150 (10.55) operating
Equivalent Output	Lb/Hr (Kg/Hr)	10,350 (4,694)
Heat Output	Btu/Hr (KCal/Hr)	10,050,000 (2,531,000)
Heat Input		11,824,000 (2,980,000)
Efficiency (fuel to steam)	%	85
Boiler Heating Surface Area	Ft <sup>2</sup> (m <sup>2</sup> )	794 (73.8)
Operational Weight	Lb (Kg)	13,200 (5,990)
Shipping Weight	Lb (Kg)	12,200 (5,530)
Combustion Control	3 position step burner HIGH-LOW-OFF	
Combustion System	Forced draft, pre-mixed burner	
Ignition System	Electric spark ignited interrupted gas pilot	
Power Supply	575, 460, or 240V, 3 phase, 60 Hz	
Max. Electrical Consumption	KVA	30.4
Blower Motor Output	HP	25
Fuel Consumption	SCFH (Nm <sup>3</sup> /Hr)	11,770 (316.5)
Fuel Supply Pressure	PSIG	3 - 5 (natural gas or propane)
Flue Gas Volume (Wet)	SCFH (Nm <sup>3</sup> /Hr)	157,000 (4,206)
Flue Gas Volume (Dry)		134,700 (3,609)
Flue Gas Velocity	Ft/s (m/s)	16.6 (5.1)
Flue Gas Temperature	°F (°C)	270 (130)
Main Steam Outlet	Inches	4" FLG
Safety Valve Outlet		2 x 2½" for boiler and optional 1¼" for economizer
Feedwater Inlet		1¼" NPT
Fuel Gas Inlet		2½" NPT
Automatic "Surface" Blowdown		2 x ⅜" NPT
Boiler & LVC Drain		1¼" NPT & 1" NPT
Chimney Diameter		26" ID
Flame Detector		Ultraviolet flame eye sensor
Overheat Protection	High tube temperature & Low water cut-off.	

**NOTE:**

- i. Equivalent output is calculated from and at 212°F (100°C) feedwater to 212°F steam.
- ii. Gas consumption based on Natural Gas with High heating value 1,004 Btu/SCF.
- iii. Thermal efficiencies are based on high heating values of fuels.
- iv. Flue gas temperature & velocity are calculated for Natural Gas with 68°F (20°C) feedwater.
- v. Boiler Safety valve Outlet size may increase if set below 170 PSIG.

1.6.11 SPECIFICATIONS FOR LXH-300 (SPECIAL)

ITEM	UNITS	LXH-300 SG
Boiler Type	Multiple water tube, once through, forced flow, steam boiler	
Boiler Horsepower Rating	BHP	290
Maximum Pressure	PSIG (Kg/cm <sup>2</sup> )	300 (21.1)
Equivalent Output	Lb/Hr (Kg/Hr)	10,000 (4,537)
Heat Output	Btu/Hr (KCal/Hr)	9,708,000 (2,446,000)
Heat Input		11,560,000 (2,912,000)
Efficiency (fuel to steam)	%	84
Boiler Heating Surface Area	Ft <sup>2</sup> (m <sup>2</sup> )	794 (73.8)
Operational Weight	Lb (Kg)	13,600 (6,170)
Shipping Weight	Lb (Kg)	12,600 (5,710)
Combustion Control	3 position step burner HIGH-LOW-OFF	
Combustion System	Forced draft, pre-mixed burner	
Ignition System	Electric spark ignited interrupted gas pilot	
Power Supply	575, 460, or 240V, 3 phase, 60 Hz	
Max. Electrical Consumption	KVA	30.4
Blower Motor Output	HP	25
Fuel Consumption	SCFH (Nm <sup>3</sup> /Hr)	11,560 (310)
Fuel Supply Pressure	PSIG	3 - 5 (natural gas or propane)
Flue Gas Volume (Wet)	SCFH (Nm <sup>3</sup> /Hr)	157,000 (4,142)
Flue Gas Volume (Dry)		129,500 (3,531)
Flue Gas Velocity	Ft/s (m/s)	17.5 (5.3)
Flue Gas Temperature	°F (°C)	320 (160)
Main Steam Outlet	Inches	4" FLG
Safety Valve Outlet		2 x 2½" for boiler and optional 1¼" for economizer
Feedwater Inlet		1¼" NPT
Fuel Gas Inlet		2½" NPT
Automatic "Surface" Blowdown		2 x ⅜" NPT
Boiler & LVC Drain		2 x 1" NPT
Chimney Diameter		26" ID
Flame Detector		Ultraviolet flame eye sensor
Overheat Protection	High tube temperature & Low water cut-off.	

**NOTE:**

- i. Equivalent output is calculated from and at 212°F (100°C) feedwater to 212°F steam.
- ii. Gas consumption based on Natural Gas with High heating value 1,004 Btu/SCF.
- iii. Thermal efficiencies are based on high heating values of fuels.
- iv. Flue gas temperature & velocity are calculated for Natural Gas with 68°F (20°C) feedwater.
- v. Boiler Safety valve Outlet size may increase if set below 250 PSIG.

## SECTION 2 ACTS & REGULATIONS

### 2.1 ACTS & REGULATIONS

There are a number of codes, standards, laws and regulations for boilers and related equipment that should be considered. Regulatory requirements are dictated by a variety of sources and are focused primarily on safety. The equipment shall be installed in accordance with the current regulations, codes and specifications of the applicable City, Country, Provincial/State and Federal agencies. Authorities having jurisdiction should be consulted before installations are made. For more information on how the various rules affect boiler selection and operation, you may want to contact your local MIURA authorized representative or the engineering firm designing the boiler installation. Here are some essential rules to consider:

- a) The boiler industry is tightly regulated by the American Society of Mechanical Engineers (ASME) and ASME Codes, which controls boiler design, inspection, and quality assurance. All boilers' pressure vessels including economizers, deaerator, blowdown tank and other pressure vessels should have an ASME stamp.
- b) All pressure vessels should be inspected and registered with the National Board.
- c) In Canada, the design of all boilers, pressure vessels, fittings, and piping must be registered with local province as required in CSA B51.
- d) The insurance company insuring the facility or boiler may dictate additional requirements. Boiler manufacturers can provide special boiler trim according to the requirements of major insurance companies such as IRI, FM. Special boiler trim items usually pertain to added safety controls. Some industries, such as food processing, brewing, or pharmaceuticals may also have additional regulations that have an impact on the boiler and boiler room.
- e) CSA/CGA, c-UL, UL approval may be required to verify boiler safety performance.
- f) A full time boiler operator may be required. Operator requirements depend on the boiler's size, pressure, heating surface area and volume of water. Boilers can be selected to minimize the boiler operator requirements; either by choosing boiler that is exempt from the rules or by installing special equipment that gives the operator more freedom in the facility. Contact the local boiler inspector for detail.
- g) Most state/province or local authorities require a permit to install and operate a boiler. Additional restrictions may apply in non-attainment areas where air quality does not meet the national ambient air quality standards and emission regulations are more stringent. Be sure to investigate these requirements before buying a boiler.
- h) Most states or provinces require an annual boiler inspection. There may be other requirements on piping as well.
- i) Most areas have established a maximum temperature at which water can be discharged to the sewer. In this case, a blowdown separator or blowdown tank is required.
- j) For all new boilers with inputs over 10 million Btu/Hr, U.S. Federal emission standards apply, including permitting and reporting procedures.
- k) Ratings of boilers are based on sea level operation. For operation at elevations above 2,000 feet (600m), equipment ratings shall be reduced at the rate of 4 percent for each 1,000 feet (300m) above sea level.

## **2.2 NATIONAL REGULATORY ORGANIZATIONS**

MIURA Boiler recommends contacting your actual insurance provider as well as the utility companies for assistance in identifying and complying with codes and regulations.

A partial list of agencies having jurisdiction over boiler installation and operation is given below. This list is comprehensive but by no means all-inclusive.

### **UNDERWRITERS LABORATORIES**

333 Pfingsten Rd.  
Northbrook, IL  
60062  
(847) 272-8800

### **CSA INTERNATIONAL**

178 Rexdale Blvd.  
Etobicoke, Ontario  
M9W 1R3  
(416) 747-2300

### **NATIONAL BOARD**

1055 Crupper Ave.  
Columbus, OH  
43229  
(614) 888-8320

### **T.S.S.A.**

3300 Bloor St., West  
4<sup>th</sup> Floor, West Tower  
Etobicoke, Ontario M8X 2X4  
(416) 325-2000

### **A.S.M.E.**

345 East 47th St.  
New York, NY  
10017  
(212) 705-7800

### **N.F.P.A.**

1 Batterymarch Park  
P.O. Box 9101  
Quincy, MA 02269-9101  
(800) 344-3555

### **INDUSTRIAL RISK INSURERS**

85 Woodland Street,  
Hartford, CT 06105-1226

### **FACTORY MUTUAL RESEARCH CORPORATION**

1151 Boston-Providence Turnpike,  
Norwood, MA 02062  
(617) 762-4300

### **AMERICAN GAS ASSOCIATION**

1515 Wilson Boulevard  
Arlington, VA 22209

### **AMERICAN NATIONAL STANDARD INSTITUTE**

11 West 42<sup>nd</sup> Street,  
New York, NY 10036

### **OCCUPATIONAL SAFETY & HEALTH ADM.**

### **ENVIRONMENT PROTECTION AGENCY**

### **LOCAL FIRE MARSHALL**

### **LOCAL BUILDING & CONSTRUCTION INSP.**

### **LOCAL BOILER INSPECTION**

### **FOOD & DRUG ADMINISTRATION**

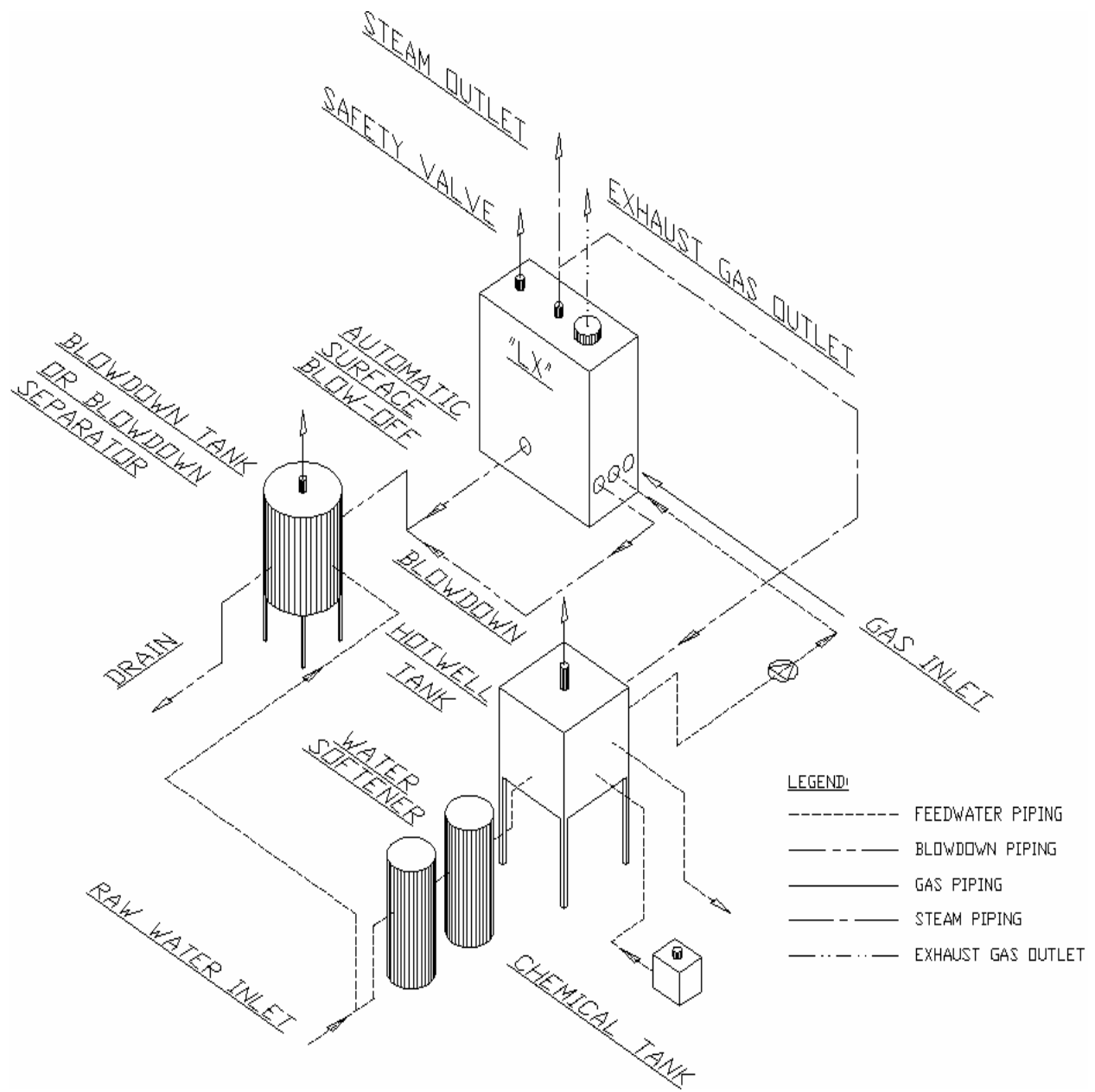

**GENERAL FLOW CHART**

## SECTION 3 INSTALLATION

**CAUTION:** All boiler prices are F.O.B. the factory at Brantford, Ontario. This means that MIURA Boiler is not responsible for damage to the boiler occurring during shipping. We strongly recommend a complete inspection of all boiler shipments at place and time of delivery. This inspection should include photographs of the boiler and ancillary equipment packing crates. If any damage is found, do not release the driver or unload the equipment until a satisfactory arrangement is made with shipping company to cover the damage. MIURA Boiler makes reasonable effort to ensure that no vibration or shock damage will occur. However, if such damage occurs and is not discovered and noted at the time of delivery, MIURA Boiler is not responsible to pay for the cost of repairs and any damaged parts will not be under warranty.

**NOTE:** It is customer's responsibility to confirm utility availability before ordering the boiler and follow all local regulations.

### 3.1 UNLOADING

For transportation the LX boiler may be disassembled and shipped in separate components as follows:

- Boiler vessel with burner and control box (Steam separator and blower assembly may be shipped separated if required by customer, except LXH-300)
- Optional Economizer (for LX(L)-50SG and LX(L)-100SG)
- External Steam separator (for LXL series)
- Optional parts such as feed water pump, silencer, filter box, steam valve etc.

**NOTE:** Some small parts, such as bolts and nuts for economizer to boiler flange or steam separator etc. will be shipped inside associated control box for the boiler.

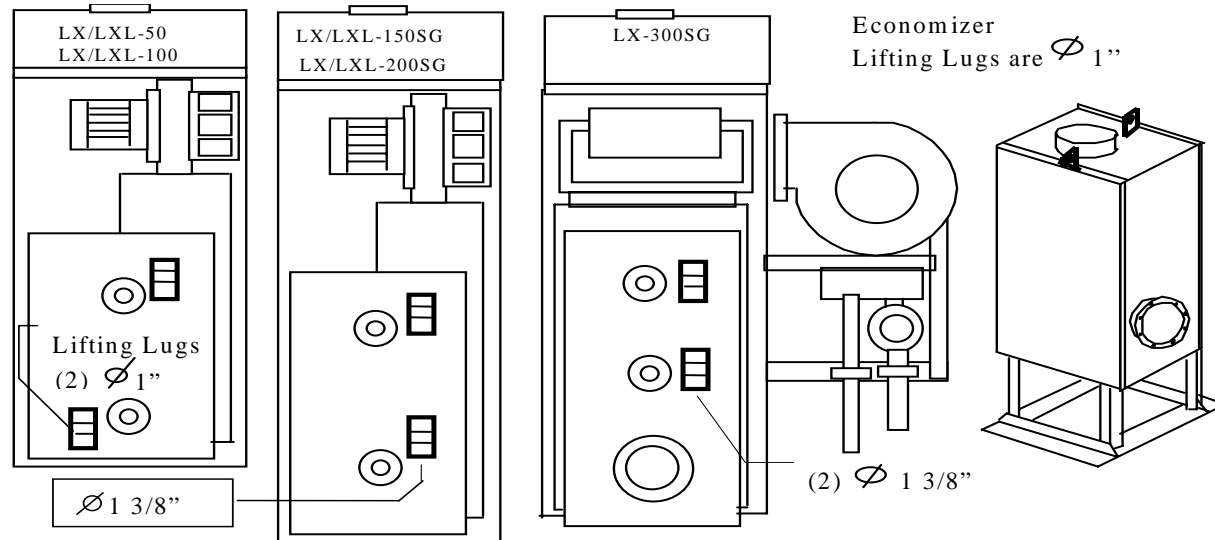

If the boiler is to be installed through an existing doorway, the Steam Separator on all models except LXH-300 may be removed at the job site. This may require a hydrostatic test on the re-assembly before the boiler is certified. If a boiler arrives at the job site and installation plans have changed, the boiler can easily be disassembled in the field to fit through the door. All other joints requiring disassembly are standard flanges with gaskets or NPT thread pipe. Ask MIURA representative for detailed information.

The LX series boiler may be unloaded from the transport truck using a forklift. However, if a forklift is used, precautions should be taken to ensure that the boiler does not tip over. The boiler is top heavy and the weight is not centered. Because of the many variables involved such as model, size of forklift and size of the loading dock, MIURA is not able to recommend a specific method of unloading the boiler. As a general starting point, the boiler center of gravity will be the midpoint of the two lifting lugs. Securing the top of the boiler to the forklift with a chain or similar methods is strongly recommended. The LX-100/150/200/300SG is shipped with the Economizer bolted to the Boiler and Boiler Skid.

## 3.2 ASSEMBLING

**CAUTION:** This is a completely shop tested, assembled and fully packaged boiler. Each unit and assembly has been well adjusted in the factory. It is very important not to make any adjustments without first consulting your nearest authorized MIURA dealer. Field reassembly is customer's responsibility.

### 3.2.1 BLOWER ASSEMBLY

Line up the blower outlet flange with the windbox inlet flange. Place the supplied rubber gasket between the two flanges. Tighten all bolts.

### 3.2.2 EXTERNAL STEAM SEPARATOR (FOR LXL MODEL ONLY)

- Install main steam outlet valve on top of the separator.
- Install the steam outlet pipe on top of the main steam valve.
- Install the steam trap to the return pipe with the flow direction to the return pipe.
- Install the external separator to the steam outlet pipe & the steam trap.
- The steam valve that is installed between the boiler separator and external separator must be fully open.

### 3.2.3 ECONOMIZER INSTALLATION (FOR SOME - S MODEL ONLY)

Adjust the economizer height as necessary to match the economizer inlet flange with boiler outlet flange by using four adjusting bolts mounted on economizer base plate. Make sure the supplied gasket is still properly glued on the boiler's chimney outlet flange. Use supplied bolts and nuts that were packed in the control box to secure these flanges together. After the boiler to economizer joint has been sealed tight, place shims under economizer base. Then bolt the economizer to the foundation slab.

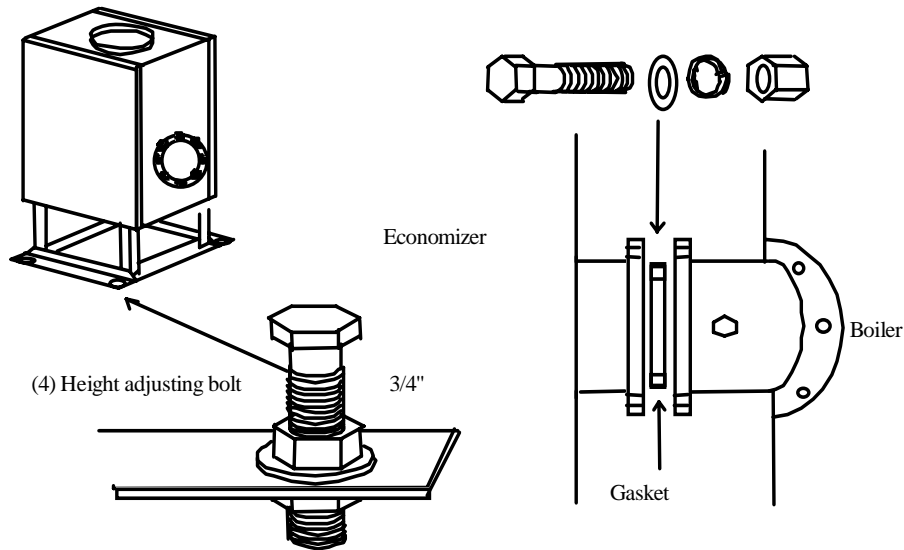

### 3.2.4 OPTIONAL FEED WATER PUMP

Feed water pump should be located under or close to the feed water tank. The suction pipe should be adequately sized and configured to minimize friction losses or air entrapment. **MIURA recommends at least six feet of water above the suction of the pump to prevent cavitation.**

The pump contactor and circuit protection provided in the control box are to be used only with feedwater pump recommended by MIURA at rated voltage and HP stamping on boiler nameplate. If different pump is used, please use external power supply and pump contact with proper protection.

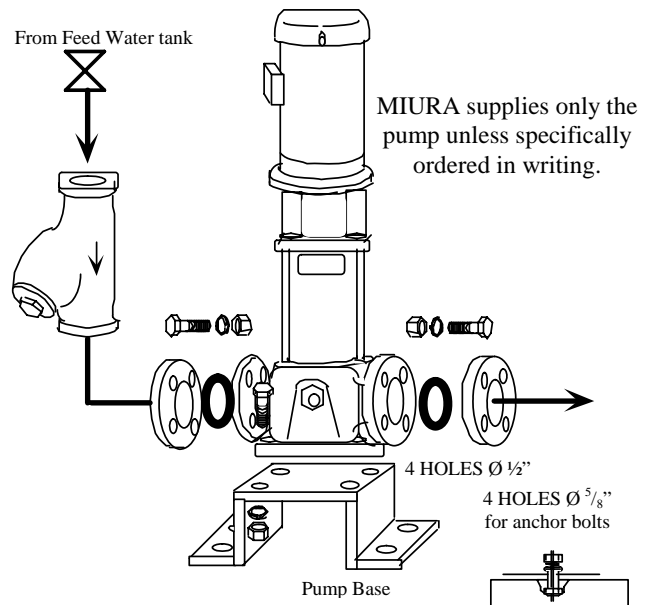

**NOTE:** Prior to installing pump, softener, and other equipment, review applicable instruction books.

### 3.2.5 FOUNDATION & ANCHORING

The recommended foundation is a 6" concrete slab. Reinforcement of the slab is not necessary if the floor is solid. After positioning, anchor the boiler, economizer, ... to the foundation using 5/8" anchor bolts (not supplied by MIURA).

**NOTE:** Installer and operator must identify emergency shut-off device, which includes power switch, main fuel, and water cock.

### 3.3 STEAM & WATER PIPING

		50	100	150	200	300
Water Inlet		¾" NPT	1" NPT			1 ¼" NPT
Steam Outlet	LX	2" NPT		3" FL 150#	4" FL 150#	
	LXL	4" FL 150#	6" FL 150#	8" FL 150#	N/A	
	LXH	N/A			3" FL 300#	4" FL 300#
Boiler Safety Valve Outlet	LX	1¼" NPT	2" NPT	2½" NPT	2x2½" NPT	
	LXL	2½" NPT	2x2½" NPT	2x4" FL 125#	N/A	
	LXH	N/A			2½" NPT	2x2½" NPT
Economizer Safety Valve Outlet		1¼" NPT (if required)				

- Safety valves for LXL boilers are optional.
- Please Contact your nearest MIURA representative or Distributor about accessories.
- Before boiler is fired for the first time after installation is completed, flush all piping. MIURA is not responsible for damage as a result of debris in piping such as stuck open check valve.
- Do not operate boiler for extended periods of time with feedwater temperature below 130°F.
- MIURA boilers do not have a manhole. All openings into the waterside of the pressure vessel are 2" standard pipe plugs.
- For installations where a Deaerator tank is installed, if expected condensate return is expected to exceed 50% of boiler capacity, a separate condensate surge tank is recommended.
- Follow all local regulations.

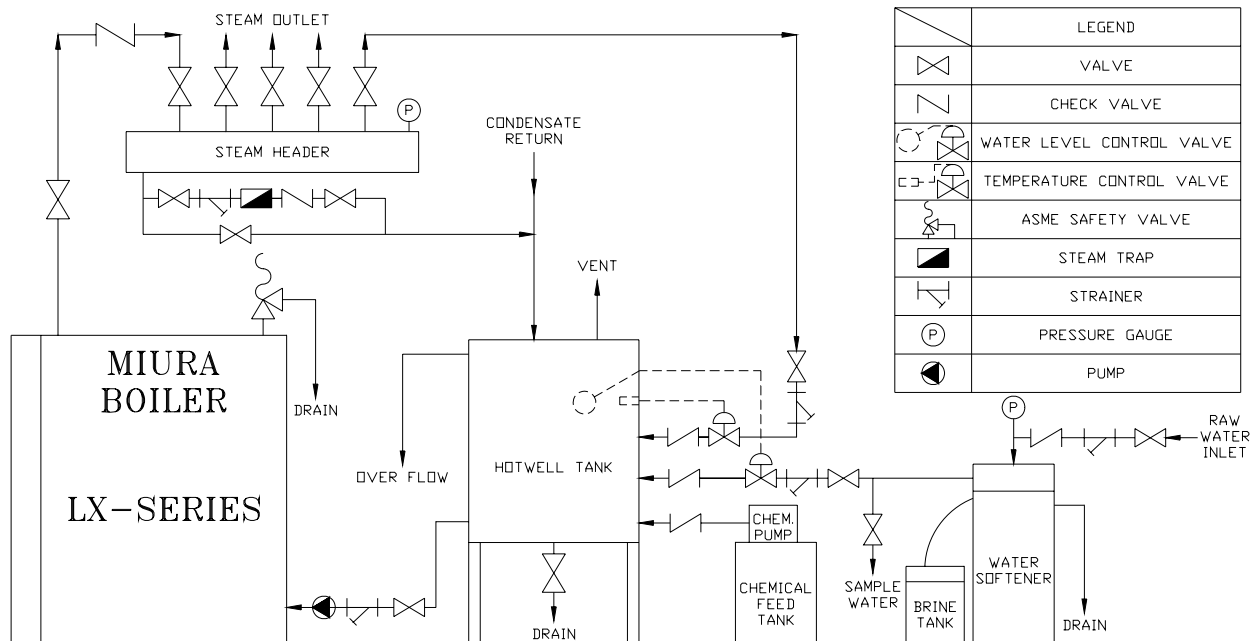

### 3.3.1 STEAM PIPING

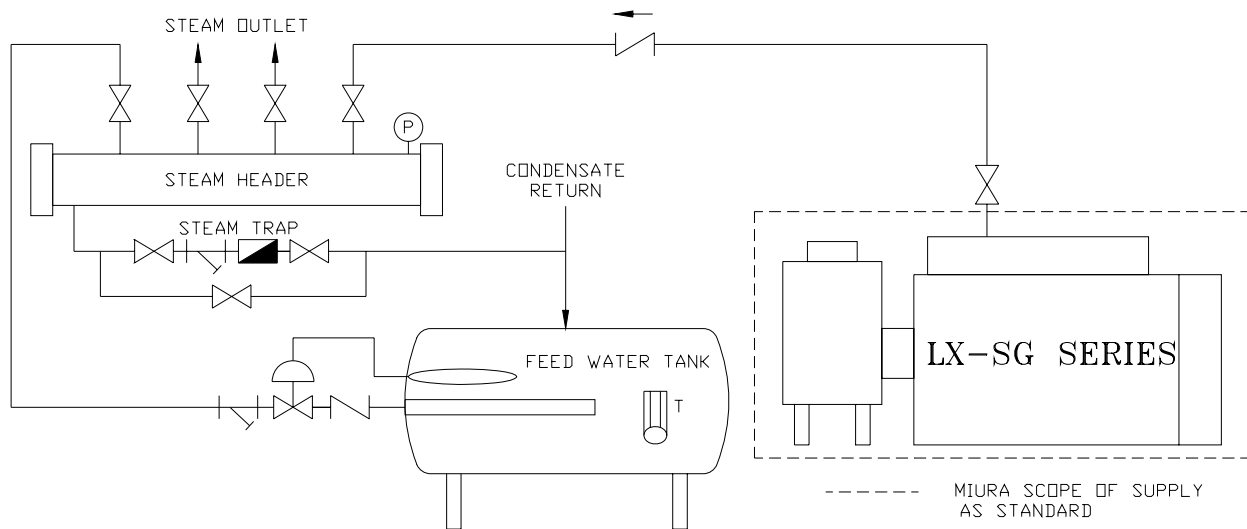

- MIURA Boiler recommends a check valve between the boiler outlet valve and the header isolation valve. Install the main steam check valve horizontally to prevent condensate build up above the check valve.
- Even though MIURA Boiler provides very dry steam, proper insulation and drainage of condensate from steam lines is still required in order to obtain dry steam at the point of use. Install the horizontal piping with sufficient slope and condensate drainage to prevent water accumulation in process steam supply piping. Recommended slope is 1" for every 200" to 300" horizontal run sloping away from the boiler. For piping runs of more than 50 feet, consideration should be given to expansion joints in the steam piping to minimize piping stress on boiler and process equipment as a result of thermal expansion of the steam piping.
- Install a steam condensate drain trap on the main steam header to remove condensate prior to distribution to process steam lines. All low points in the steam piping should also have a condensate removal trap installed. This will minimize the chances of damage caused by water hammer or poor temperature control of the process due to water slugs in the steam system. Standard steam system practice is to install a steam trap every 75 feet of piping run. Ask your steam trap provider for details
- It is recommended to have a feed water preheated system whether there is sufficient condensate return to maintain temperature or not. A feed water pre-heat system is NOT required for the MIURA boiler. However, a pre-heat of the feed water will maintain high, steady feed water temperature, reducing the amount of oxygen in the feed water and therefore the amount of oxygen scavenging chemicals required. Some chemicals used may also require maintaining a minimum temperature in the feed water tank. Please check with your chemical supply company.

### 3.3.2 FEED WATER SYSTEM PIPING

**NOTE:** Important factors to properly size the water softener are: raw water hardness, conductivity, make-up water volume, boiler operating hours and water iron content. For details and assistance, please contact your nearest MIURA representative or boiler water treatment chemical company.

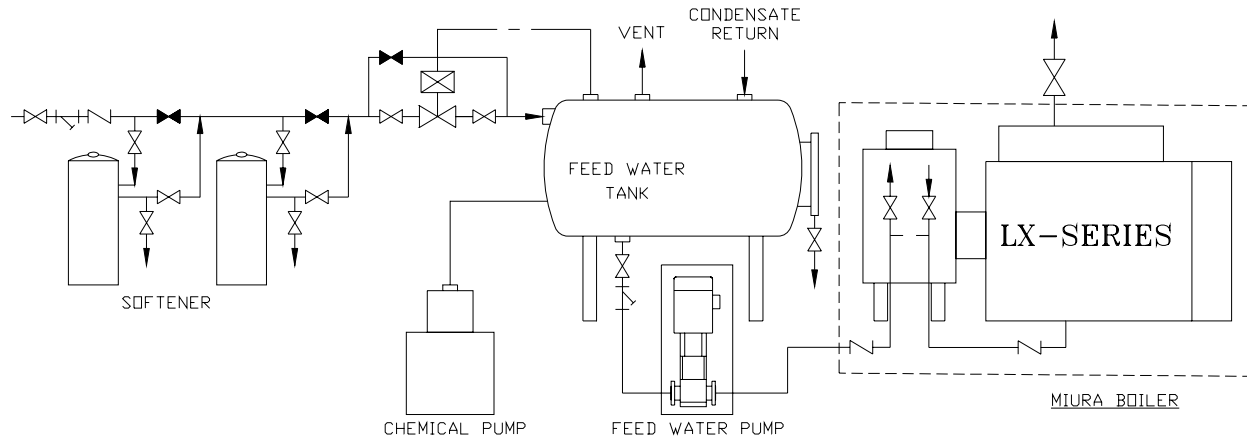

- **Zero PPM hardness and daily sampling are required at feed water tank.** Use a test kit with a minimum sensitivity of one PPM. Do not connect the hard water line to the condensate return line.
- Install softener in series; dual units are recommended. If water softeners are not installed in series, a full size polisher is recommended. Avoid a system that allows low flow rates through softener resulting in channeling of ion exchange medium. **Confirm water pressure to ensure less than 1 PPM at all times.** Typically minimum water pressure of 30 PSIG at all times is required, check with your water softener supplier for details. Use a Make up water control system that will only allow specified flow through the Softener. The rule of thumb is ½ GPM minimum flow for each 1 cubic foot of resin in the softener tank. Consult chemical treatment company for specifics.
- Test cocks for individual softener and Feed Water tank water quality testing are strongly recommended.
- Keeping a daily log of water softener, deaerator and boiler water is highly recommended.
- Collect condensate from process as feasible. Return condensate to Feed Water tank. Do not connect any piping that would allow hardness or product to enter Feed Water tank. Thermal insulation is recommended for all piping between Feed water tank and Boiler to conserve heat.
- Run all drains and overflows to floor level with an air gap to provide inspection capability.
- Use a gate valve or ball valve in the Feed Water pump suction line followed by the specified strainer.
- Install the Feed water pump under or near the Feed water tank. The suction pipe should be adequately sized and configured to minimize friction losses. **MIURA requires at least six feet of water above the suction of the pump to prevent cavitation.** Avoid high points in the pump suction piping that would allow air to collect and result in loss of pump priming.

- Ensure the height of the water level in the feed water tank is sufficient to prevent cavitation of the feed water pump under normal operating conditions. In general, MIURA Boiler recommends installing the Feed Water supply tank as high as possible in the boiler room to prevent any possibility of Feed Water Pump Damage due to cavitation. Specifically MIURA requests that the tank water level be at least 6 feet above the pump suction.
- In some cases, a flow restricting plate may be necessary to prevent cavitation of the feed pump when re-filling the boiler after a bottom blow down. If the boiler will not be operated over 100 PSI, the plate may also be necessary. If the tank supplying water to the boiler is not more than 6 feet above the pump, a plate will be required.
- Dual pump feed water systems is available as an additional option.
- Some jurisdictions require a pressure gauge on the discharge of the pump.
- Chemical feed can be made to feed tank and/or feed water line. All MIURA Boilers are provided with a set of “DRY” contacts through terminal strip connections W8 and W9. These wires connect a Normally Open contact on the feed water pump magnetic contact. MIURA recommends wiring the chemical injection pumps through this contact. This allows the chemical injection pumps to operate only when the feed pump is running. This type of operation allows the chemical company to adjust chemical usage directly to the boiler water usage. Due to the very small water content of the boiler any difference between chemical injection rate and steaming rate will result in erratic chemistry control. Operating the Chemical pumps concurrently with the feed pump will provide a more consistent use of chemicals.
- Chemical Treatment procedures should be based on recommendations of reputable boiler water chemical treatment company. NONE of the MIURA Boiler Warranties cover damage to the pressure vessel due to corrosion or formation of scale.
- Follow all local regulations

### 3.3.3 *OPTIONAL FEED WATER PUMP*

**CAUTION:** The feed water pump is vital to satisfactory operation of your new MIURA Boiler. Review this section carefully for pump selection criteria if customer has chosen to purchase a pump from other than MIURA. All pumps, regardless of manufacturer, require a positive pressure on the pump suction to prevent cavitation damage to the pump. Any damage to the pump resulting from installation errors or cavitation is NOT covered by MIURA.

**DANGER:** MIURA Boiler is a unique design; common pump sizing criteria do not apply. Improper sizing of feed water pump will severely impact the performance of the MIURA Boiler. Under-sizing of the pump either by flow or by pressure will result in frequent Low Water Alarms and Boiler Lockouts. If this condition is allowed to continue, the Manufacturers Warranty on the pressure vessel DOES NOT COVER any tube damage that may result. Review and FOLLOW the pump sizing criteria given below and this condition will not occur.

MIURA boiler recommends that a pump be purchased with the boiler rather than using an existing pump. The reason for this is that MIURA Boilers run with intermittent feed water pump operation. MIURA Boilers start the feed pump on call for water and then turn it off when call for water stops. This is due in part to the boiler having no fixed steam/water level to maintain and in part, due to a side benefit of the pressure vessel design. Most other boilermakers require operating the pump continuously using a modulating feed water control system such as McDonnell Miller float valves. This is done mostly to reduce thermal stresses on the boiler shell that result from the introduction of relatively cold water to the hot boiler. It is also partly because they have a fixed steam/water level. The MIURA Design Advantage eliminates the need for this type of system. MIURA simply turns the pump on and off as needed based on actual boiler steam demand. This allows the pump to always run at optimum efficiency and prevents pump-overheating problems. The MIURA Boiler is designed, tested and CERTIFIED to operate this way. Experience has shown there is no advantage to operating a MIURA Boiler with a modulating Feed Water Control system.

Therefore, if a pump other than that provided by MIURA is used, the following selection criteria is provided: Size the pump to deliver twice (2X) or preferably three times (3X) the steady state evaporation rate of the boiler. This flow MUST be delivered to the boiler at a pressure AT LEAST 30-psi ABOVE the Boiler operating pressure. Also, ensure that the pump motor is able to handle frequent start/stop cycles without overheating the motor windings.

MIURA recommends using Grundfos series C multi-stage centrifugal pumps. Pumps should be installed in accordance with the manufacture’s instruction booklet in order to operate efficiently and provide years of service. The pumps are water lubricated and do not require any external lubrication or inspection. The motors will require periodic lubrication as noted in the maintenance schedule section. The pump is a close coupled, multistage high-pressure centrifugal type. Pump models vary with the horsepower of the boiler and are selected for operation at 150 PSI steam pressure on LX model. If lower pressure is desired, a flow restricting plate or smaller pump may be appropriate.

Boiler Model	Pump Desired Capacity	Grundfos Pump Model	Boiler Operating Pressure
LX-50	8 GPM	CR2-100U 3HP or CR3-13U 3HP	150 PSI
LX-100	16 GPM	CR2-120U 3HP or CR3-17U 3HP	
LX-150	24 GPM	CR4-120U 5HP or CR5-16U 5HP	
LX-200	32 GPM		
LX-300	48 GPM	CR8-100U 7.5 HP or CR10-10 7.5 HP	
LXL-50	8 GPM	CR2-40U 1HP or CR3-3U ½HP	15 PSI
LXL-100	16 GPM		
LXL-150	24 GPM		
LXL-200	32 GPM	CR4-40U 1.5HP or CR5-4U 1.5HP	
LXH-200	32 GPM	CR10-12 10HP	230 PSI
LXH-300	48 GPM	CR8-160U 15 HP or CR10-17 15HP	280 PSI

**CAUTION: Under no circumstances should the pump be operated without flow through the pump. Do not allow the pump to vapor lock. Severe and immediate damage to the pump will result.**

Dry operation of the pump is prohibited. This can result in motor and pump damage due to overheating. A properly sized re-circulation flow fitting may be obtained from Grundfos and installed to prevent this damage, if the pump is run with an isolation valve that is closed.

MIURA boiler operations exceed the number of start/stop cycles for the pumps, which is specified in the Grundfos Installation and Operating Instructions. The number of start/stop cycles in conjunction with the short running times in our application, is approved by Grundfos and MIURA Boiler Engineering Department and will not result in motor overheating problems.

For detailed installation data, refer to Grundfos Installation and Operating Instructions that were supplied with the pump. The pump is in a separate crate from the boiler.

MIURA recommends installing a feed water suction strainer of at least 20 mesh. Install a strainer at least one size larger than pump suction piping. Pump flange kits are available from MIURA as an option. Also, install an isolation valve on the supply side of the strainer to allow cleaning the strainer without draining the feed water supply tank. The Suction side isolation valve and feed water strainer are NOT provided by MIURA, but must be installed in order to include the pump in the One-Year parts Warranty. The One-year warranty applies to the pump ONLY if it is purchased through MIURA.

Before starting the pump after initial installation or maintenance, please check the following:

- All piping connections are tight and the pipes are adequately supported.
- Any isolation valves on the suction of the pump are open.
- Pump is primed and vented through the vent fitting located at the top of the pump.
- Open the main power disconnect. Remove the coupling guard and rotate the pump shaft to be certain it turns freely. Replace the coupling guard.
- Insure that all feed water isolation valves are open.
- Shut the main power disconnect to the boiler.
- While observing the top of the pump, cycle the boiler “ON-OFF” switch located on the front of the boiler. This will start the pump and allow verification of the direction of rotation. Direction of rotation is counterclockwise when viewed from the top. The pump will not run if the control switch is in the “OFF” position.

### *3.3.4 OPTIONAL FEED WATER CONTROL VALVE*

In the application where the customer does not want to operate the feed pump in frequent start/stop cycles, other options are available. Again, the feed system operates in a simple On-Off manner. If control valves are used, they MUST be quick acting (within 5 seconds). MIURA recommends ball valves with pneumatic actuators (preferred) or electric actuators (acceptable). Note that the pneumatic actuators operate in 1 second open to shut and the electric actuators are 5 seconds open to shut. Electric feed water control valves are available as an option on all boiler models.

**DANGER: Any proportional feed water actuator or control valve that operates slower than 5 seconds from shut to fully open is not acceptable and will cancel all warranties.**

### 3.3.5 SAFETY VALVES

Drip pans (may be supplied by MIURA if requested) should be used for boiler safety valves. Water that collects in the elbow and valve body after the valve lifts, any rainwater or valve leakage should be drained off and not allowed to stagnate. Failure to drain the water may result in valve corrosion or water

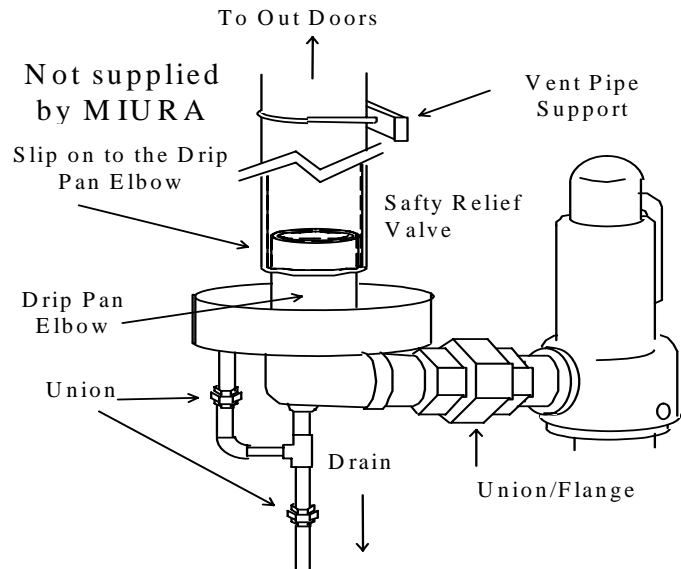
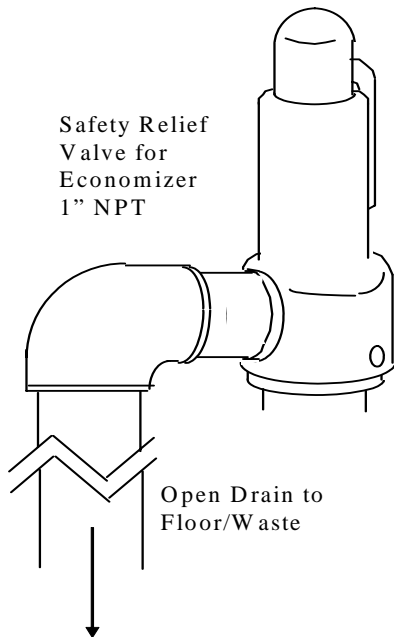

hammer if the valve lifts.

The optional economizer may be equipped from the factory with a safety valve. The economizer safety valve may not be required to be piped to the roof depending on local codes. Piping should be directed to a floor drain or other collection points as specified by the local codes concerning boiler wastewater. The water discharged by this safety may be near or at the boiling point and could cause a potential for personnel injury. Arrange the piping accordingly.

### 3.4 BLOWDOWN PIPING

		50	100	150	200	300
Blowdown Tank Minimum Diameter	LX & LXH	18"		24"		30"
	LXL	N/A				
Blowdown Tank Minimum Volume	LX & LXH	5.8 cu Ft	8.7 cu Ft	17.3 cu Ft		46.3 cu Ft
	LXL	N/A				
Blowdown Tank Minimum Pressure	LX	51 PSI				
	LXH	90 PSI				
Boiler Manual Bottom Blow-off Outlets	LX & LXL	1" NPT				1 1/4" NPT
	LXH	N/A				1" NPT
Boiler Automatic Surface Blowdown Outlet		3/8" NPT				2 x 3/8" NPT
LVC Drain Outlet		1" NPT				

Minimum dimensions and pressures of blow-off tank are based on CSA B51-95 - Boiler, Pressure Vessel, and Pressure Piping Code.

**DANGER:** Be sure to install blowdown piping separately from overflow and drainage piping. Piping shall be arranged to prevent any possibility of water splashing, causing personal injury.

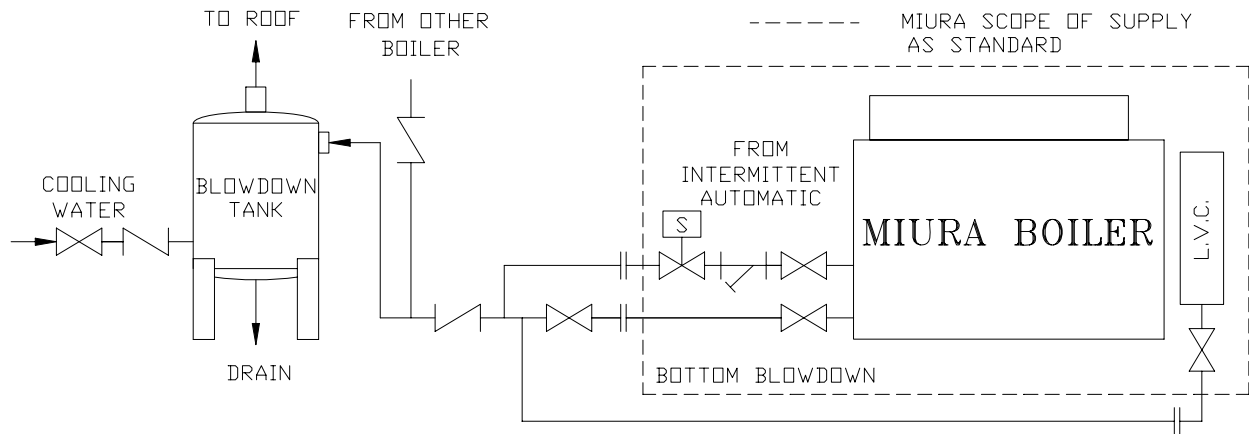

All piping subject to pressure from the boiler during blowdown must be securely anchored to prevent piping vibration and shock during blowdown of the boiler. Due to the large number of different piping arrangements possible, MIURA recommends a maximum pressure for manual bottom blowdown of 30 PSI.

**DANGER:** Note that the Automatic Surface blowdown line operates automatically when the boiler is at high pressure and temperature. Therefore the 3/8" pipeline must be piped to the blowdown tank to avoid personal injury.

Do not allow siphoning back into the boiler from wastewater drains.

Standard equipment includes one quick opening ball valve for blowdown isolation. Additional "Y" pattern slow opening blowdown isolation valves may be installed at customer request and as required by local regulations.

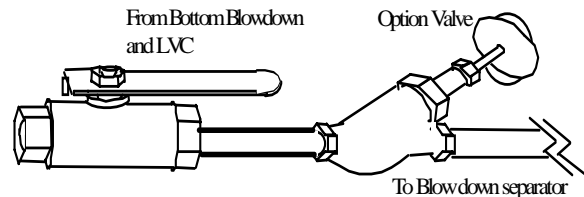

MIURA recommends installing an additional check valve between the automatic blowdown solenoid valve and the blowdown separator. Check valve is not included with boiler.

A blow-off vessel or Miura Blowdown Separator shall be placed between the boiler and sewer, where the blow-off from any boiler having working pressure exceeding 15 PSI is discharged into

a sewer system. This is to reduce the temperature of the water entering the sewer system to a maximum of 150°F. MIURA Boiler may supply Blowdown separator after cooler control at customer request. Ensure that local regulations for disposal of boiler wastewater are followed.

In an installation where multiple boilers share a common blowdown separator, install a check valve in the piping between each automatic and manual blowdown isolation valves and the blowdown separator.

In a situation where all blowdown water is collected in a sump, size the sump for at least five times the operational water content of the boiler. This will allow collecting the boiler water and the cooling water used by the blowdown separator. The operational water content is provided in the general specification tables.

Follow all local regulations.

### 3.5 FUEL PIPING

FUEL TYPE: Natural & Propane Gas  
 SUPPLY PRESSURE: 3 - 5 PSIG \*

**NOTE:** 3 – 5 PSIG is the setting range, NOT the allowable fluctuation range. Maintain steady, set gas supply pressure within 0.2 PSIG but NEVER below 3 PSIG during operation. This pressure must be at the regulator supplied with MIURA Boiler gas piping. If necessary, use larger pipe for long piping runs. Failure to maintain required gas flow rate pressure will result in frequent boiler misfire!

**NOTE:** Do not use any gas piping with a diameter smaller than the gas inlet piping to boiler. All main gas train piping to the burner is included, (except for individual regulator and pressure switch vents).

**CAUTION:** Do not attempt to change any part of this gas train without first consulting the nearest authorized MIURA representative.

	LX(L)-50	LX(L)-100	LX(L)-150	LX(L,H)-200	LX(H)-300
Gas Inlet	1½" NPT	2" NPT		2½" NPT	
Main Regulator Vent	1" NPT				
Pilot Regulator Vent	¼" NPT				2 x ¼" NPT
Pressure Switches	2 x ¼" NPT (some switches model may not require vent)				
Automatic Vent (option)	¾" NPT	1" NPT			

See specification tables for fuel consumption.

Supply pressure of 3 to 5 PSIG is required at boiler regulator inlet at full firing rate and when boiler combustion is stopped. Installation of a pressure gauge to monitor gas supply pressure is recommended. If the boiler is operated with propane fuel, MIURA Boiler STRONGLY

recommends the use of a vaporizer. Collecting the propane gas from the top of the tank is possible, but not recommended due to variations in vapor space pressure depending on ambient air temperature. Also, ensure the vaporizer is sized for full boiler capacity even if the normal load is less than the maximum capacity of the boiler. This recommendation is based on the boiler operating at full rated fuel flow during the start up period.

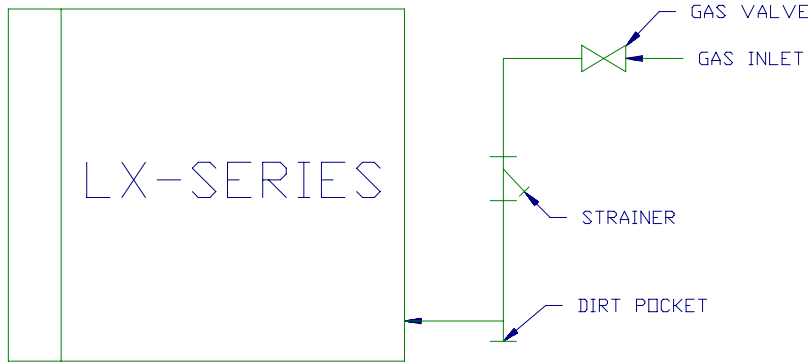

If the supply gas pressure is above 5 PSIG, use only one approved reducing station per boiler room to meet the required specifications. Do not use a separate reducing valve to supply each boiler. This would result in pressure oscillations that could result in boiler flame failures or momentary over firing conditions. Consult pressure regulator application engineers for correct sizing and regulator model selection. Use an approved booster pump, if necessary, to meet the required minimum pressure specifications of 3 PSIG. To ensure an adequate volume of fuel is available to support combustion during firing rate changes, a 3 PSIG minimum is required at the inlet to the boiler main regulator supplied with the boiler. Specifically, a change from burner Off to Low Fire, which is approximately 40% of rated fuel usage, occurs over a 10-15 second period. The fuel usage then goes from 40% to 100% rated consumption when the boiler goes to high fire. This change occurs in less than one second. Fuel consumption then changes from 100% to zero in less than one second when the boiler turns off. The utility gas regulator must maintain at least 3 PSIG and not exceed 5 PSIG under these conditions, and is to be installed as far away from the boiler regulator as possible. The maximum pressure of 5 PSIG is determined by UL and CSA

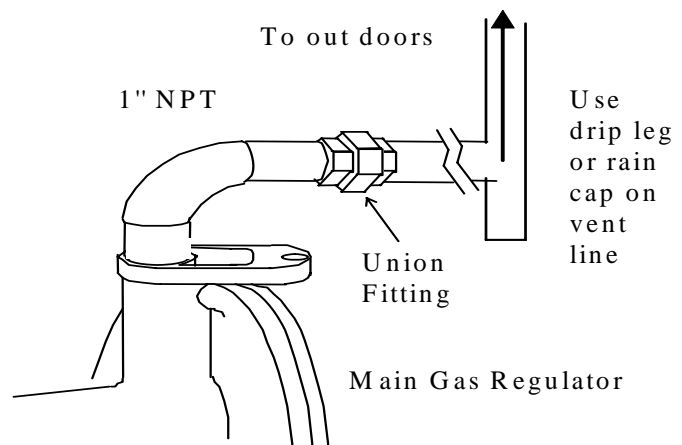
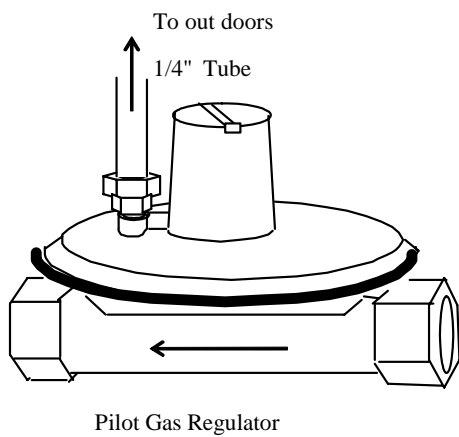

company for details.

approval of the MIURA standard gas train. Consult gas

The Copper gas line to the pilot regulator is tin lined and does not require replacement in jurisdictions that prohibit use of Copper tubing on natural gas piping. The pilot gas regulator is required to be vented outside. Do not allow line to be crimped; frequent pilot flame failures will result.

Install dirt pocket on Main gas inlet piping immediately up stream of boiler.

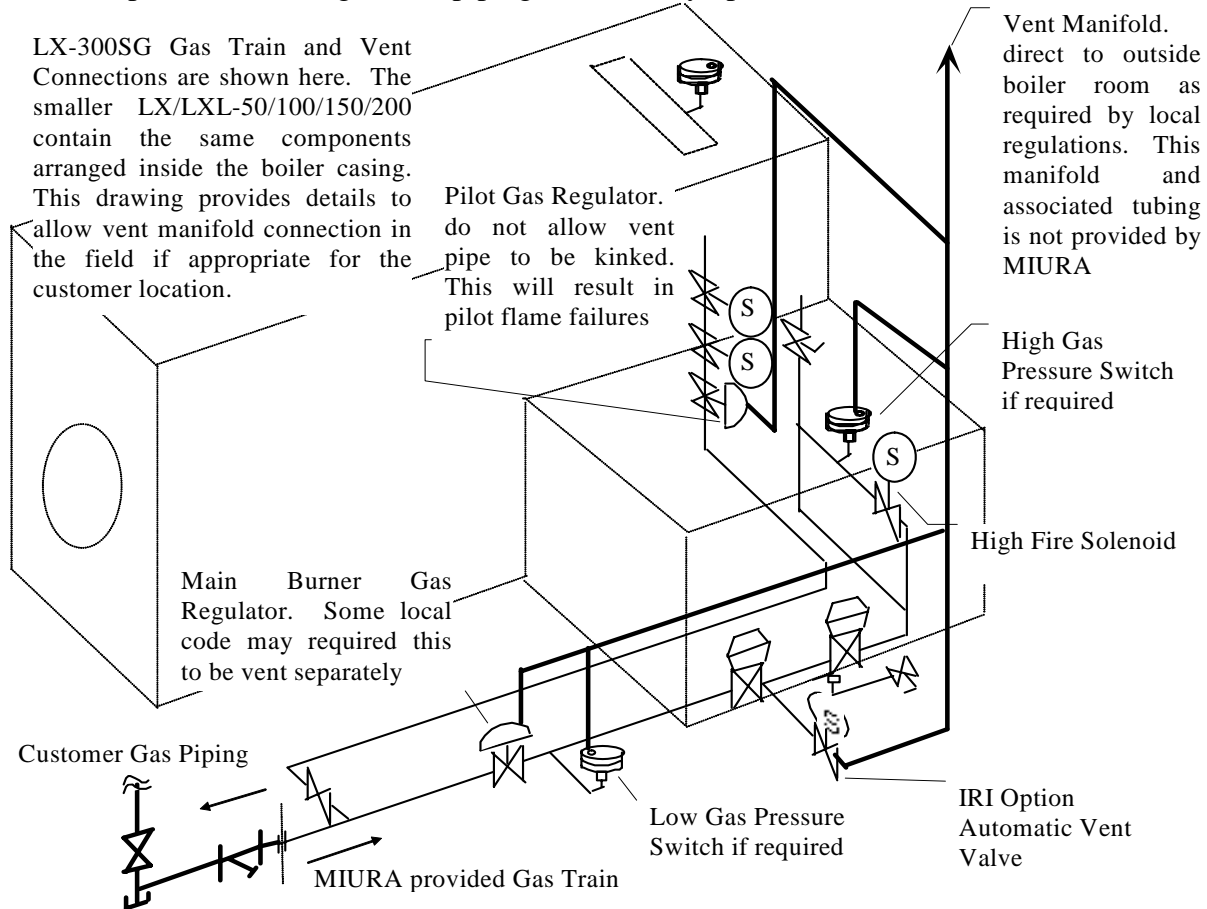

Two pressure switches, HIGH and LOW gas pressure, may be required to be vented to the atmosphere outside of the boiler room. Contact your local insurance provider and the Gas Company for specific requirements. Note that some boiler models may have ANTUNES RLGP-G 5~30" switches on the gas train which do not require venting to the atmosphere.

Typically, gas vent lines can be connected to a common vent line. The vent line will have a cross-sectional area not less than the area of the largest vent line, plus 50 percent of the areas of all the additional vent lines. Do not allow vent line to be blocked or fill with rainwater. Boiler operation will be adversely affected.

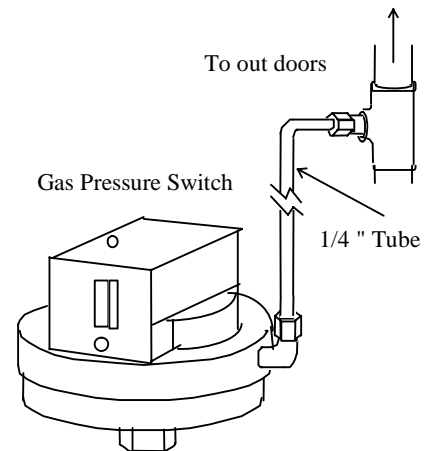

An optional solenoid automatic vent valve located between the main gas blocking valves may be required for insurance purposes and is an additional cost option to meet IRI specifications. Ensure IRI is specified on the purchase order if necessary.

Follow all local regulations.

### 3.6 CLEARANCES & VENTILATION

#### 3.6.1 CLEARANCES

The LX model is designed for non-combustible floors with minimum clearances from the unit and the flue connector to combustible materials of:

Boiler Top	40 inches	(1,020mm)
Boiler Right Side	24 inches	(610mm)
Boiler Left Side	24 inches	(610mm)
Boiler Rear	24 inches	(610mm)
Boiler Front	48 inches	(1,220mm)

Follow all local regulations

#### 3.6.2 VENTILATION

The table below gives factory recommended minimums for ventilation of each boiler. The recommendation is based on Canadian Gas Association standards. However, please confirm with local building and safety codes as boiler room ventilation requirements vary by significant amounts. For multiple boiler installations, multiply the below areas by the number of boilers installed in the boiler room.

BHP	SUPPLY AIR AREA (sq. in.)	VENTILATION AIR AREA (sq. in.)	CHIMNEY DIAMETER (inch)
50	70	10	12
100	140	14	14
150	210	21	14
200	280	28	20
300	420	42	26

Ventilation of the space occupied by the boiler should be provided by at least one opening directly in contact with the outdoors. Such an opening is to be located at the highest practical point for the purposes of generating natural convective processes of air circulation. The total cross-sectional area of such openings shall be at least equal to those in the table above.

In addition to the required openings for required air ventilation, there shall be a permanent air supply via openings having a total cross-sectional area not less than what is required from the table above. The location of these openings shall not interfere with those openings intended for the

purposes of ventilation. These supply air openings shall be either located at, or ducted to, a point not more than 18 inches (450 mm), and not less than 6 inches (150 mm), above the floor level.

### 3.7 STACKS AND BREECHING INSTALLATION

**NOTE:** Consultation with your Engineering Company or Exhaust Stack provider will ensure a long lasting trouble free stack design. The stack must be designed to maintain available draft at the outlet of the boiler between zero to -0.05" of water throughout the whole firing range (i.e. for four boilers; all boilers at high-fire or only one boiler at low-fire). Failure to maintain this value will adversely affect boiler performance and is not the responsibility of MIURA.

Each boiler should be equipped with a single stack. If this is not possible, Barometric dampers or equivalent are required to prevent exceeding maximum draft on the boiler.

Proper installation of the chimney is required for good boiler efficiency and safe operation. The following principles should be followed at all times when designing chimneys:

1. Chimneys should be straight. Bends or offsets have more resistance to flow with consequent adverse effects on burner performance and should be avoided whenever possible.
2. A stack should be higher than nearby structures to avoid down drafts or eddy current. If this is not possible, a stack hood designed to prevent downdrafts should be considered.
3. The stack should project at least:
  - a) Two feet above the horizontal plane drawn from a point at least 10 feet away from the stack; and
  - b) Three feet above the lower side of the roof slope.
4. Include a rain hood for all stacks. In addition, be sure to add a rain shield for straight stacks through the roof.
5. Do not make the stack diameter smaller than the flue gas outlet on the boiler.
6. Provide supports if the stack exceeds 100 lbs. Also, clamp the stack firmly to the flue gas outlet.
7. Install the stack away from any combustible materials and utilize insulation at the opening in the wall or roof. Flue gas sample fittings are provided from the factory on boilers ordered

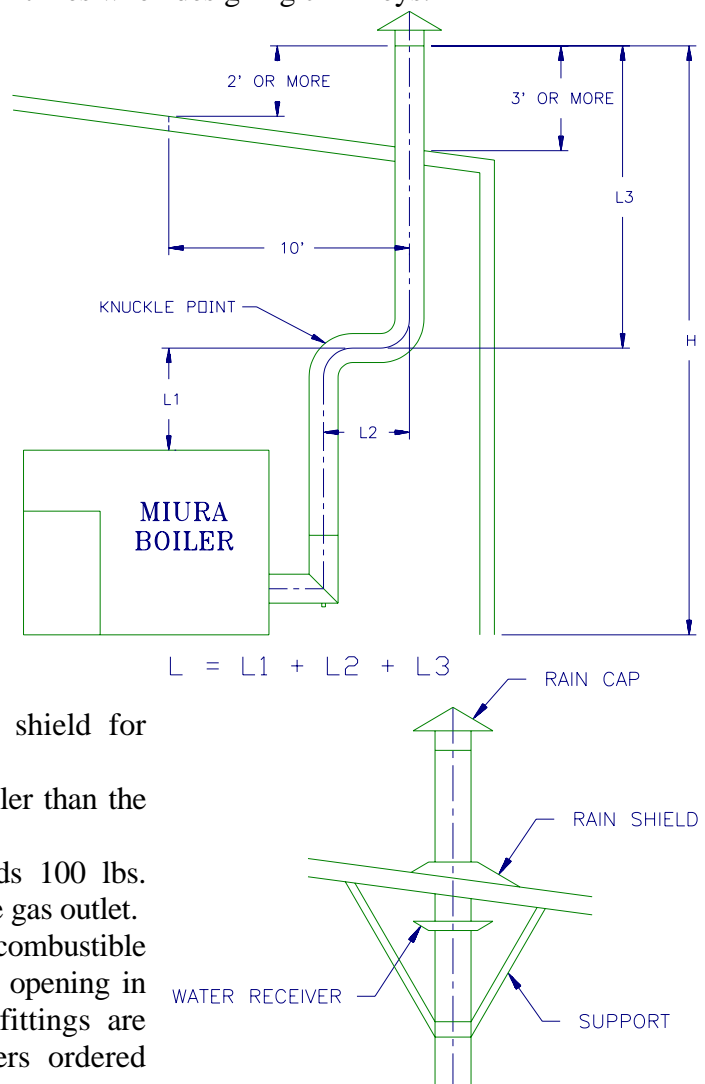

with economizers. In addition, flue drain connections are provided on the exhaust elbow or economizer. Ensure these connections are piped to drains. Please do not cover these fittings when insulating the exhaust stack.

8. One, ½” drain plug fitting is installed on the optional MIURA flue elbow and one, 2” drain coupling is provided on the optional economizer. The 2” drain coupling is intended to allow piping of condensation to a floor drain through a “J” type water trap. Do not connect these drain holes with any blowdown piping.
9. When the boiler is installed in regions where temperatures fall to the freezing point, a stack damper should be installed to prevent down drafts from freezing the boiler tubes when it is not in operation. In addition, a chimney down draft will have a direct effect on main burner ignition reliability.
10. Follow all local regulations. Check your building, fire and mechanical codes as a minimum guideline.

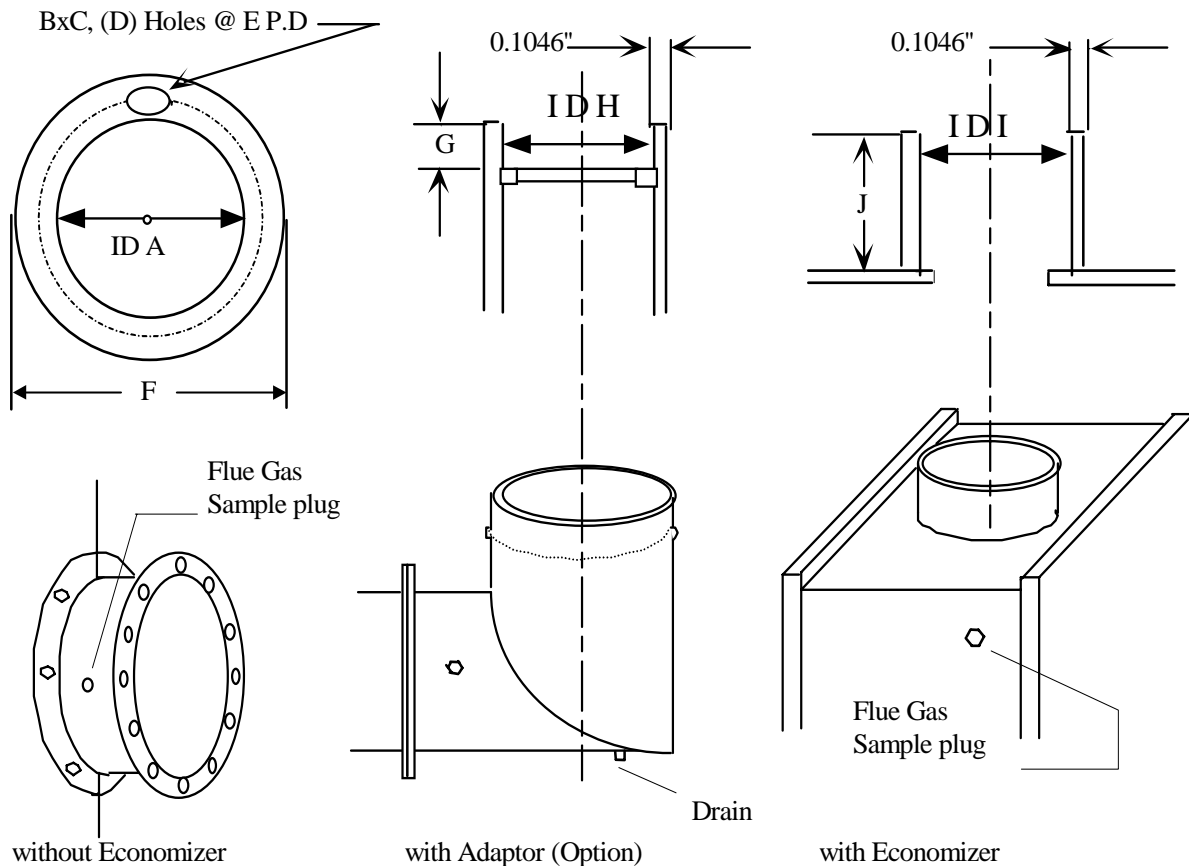

## FLUE GAS OUTLET DIMENSION

BHP	50	100	150	150 & 200	300
A	11¾"	13"		19"	25"
B x C	5/8" x 1 1/8"				
D	8	12		16	
E	13½"	16"		22"	28 3/8"

BHP	50	100	150	150 & 200	300
F	15"	18"		24"	30"
G	1½"				
H	12"	14"		20"	26"
I					
J	4"		6"		

The equation below states the relationship between chimney draft and the pressure drops of flue gas.

$$0.82H > 0.49L + 1.5N + 1.5$$

H: Height of chimney end (Ft)

L: Total length of chimney (Ft)

N: Quantity of knuckle points.

$$0.25H > 0.15L + 1.5N + 1.5$$

H: Height of chimney end (m)

L: Total length of chimney (m)

N: Quantity of knuckle points.

Please ensure the above equation is satisfied in order to obtain the full capacity of the LX-Series.

## STANDARD EMISSION FOR MIURA LX SERIES BOILER

	Stack Temperature	O <sub>2</sub>	NO <sub>x</sub>	CO
LX-G	500°F	5% ± 1%	< 20 PPM	< 100 PPM
LX-SG	300°F			
LXL-G	500°F			
LXL-SG	300°F			
LXH-200SG	320°F			
LXH-300SG	320°F		< 25 PPM	

These data are based on shop test boiler with 70°F feed water temperature and 70 PSIG steam pressure at high-fire rates. NO<sub>x</sub> and CO are corrected to 3% O<sub>2</sub> based on Natural Gas combustion.

**NOTE:** The LX Boilers can meet current SCAQMD codes if required by purchase order.

### 3.8 ELECTRICAL INSTALLATION

**NOTE:** MIURA recommends that an Alarm or Caution light be installed in the control room if possible.

	Voltage (V)	Input Rate (A)	Wire Gauge (AWG)	Disconnect Amperage (A)	Electrical Consumption (KVA)
LX-50	575	6.9	#14 x 3 + #14G	15	6.8
	480	8.5			
	230	17.0			
LX-100	575	13.1	#10 x 3 + #14G	30	13.4
	480	16.8			
	230	32.6			

	Voltage (V)	Input Rate (A)	Wire Gauge (AWG)	Disconnect Amperage (A)	Electrical Consumption (KVA)
LX-150 LX-200	575	19.7	#10 x 3 + #10G	30	20.0
	480	25.1			
	230	49.2	#6 x 3 + #8G	60	
LX-300	575	30.6	#8 x 3 + #10G	40	30.4
	480	38.1	#6 x 3 + #10G	60	
	230	77.2	#3 x 3 + #8G	100	
LXL-50	575	5.2	#14 x 3 + #14G	15	5.0
	480	6.3			
	230	12.6	#10 x 3 + #12G	30	
LXL-100	575	11.4			
	480	14.6			
	230	28.2	#8 x 3 + #10G	40	
LXL-150 LXL-200	575	17.0	#10 x 3 + #10G	30	17.0
	480	21.4			
	230	42.0	#6 x 3 + #8G	60	
LXH-200	575	25.1	#10 x 3 + #10G	30	25.0
	480	30.0	#8 x 3 + #10G	40	
	230	62.7	#4 x 3 + #8G	90	
LXH-300	575	39.7	#8 x 3 + #10G	40	36.7
	480	48.4	#6 x 3 + #8G	60	
	230	97.8	#2 x 3 + #6G	120	

- Other voltages are available by special order.
- Optional equipment such as MIURA Multiple Installation (MP1/MT1-200) system must be wired as specified in the individual instruction books.
- After installation of the feed water pump and blower to the foundations the motors must be wired to the boiler power distribution box, using customer provided cables. If the pump or blower is located some distance from the boiler, an emergency stop/start or disconnect switch may be required near the motors. Check rotation direction of blower, feedwater pump, and oil pump.
- Comply with local building electrical codes.

**CAUTION:** MIURA boiler is supplied with a motor controller for the boiler feed water pump. The optional feed water pump should be powered from the boiler. If the pumps and motor controller were supplied with the de-aerator or hotwell tank, use the two terminals identified on wiring diagram as the remote ON-OFF switch for the pump. The feed water pump should be located as close as possible to the water source to minimize risk of cavitation.

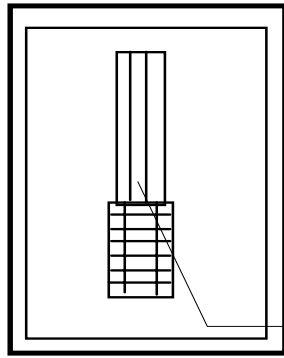

LX/LXL-50/100  
Power Box

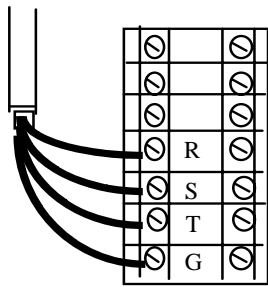

Terminal Strip

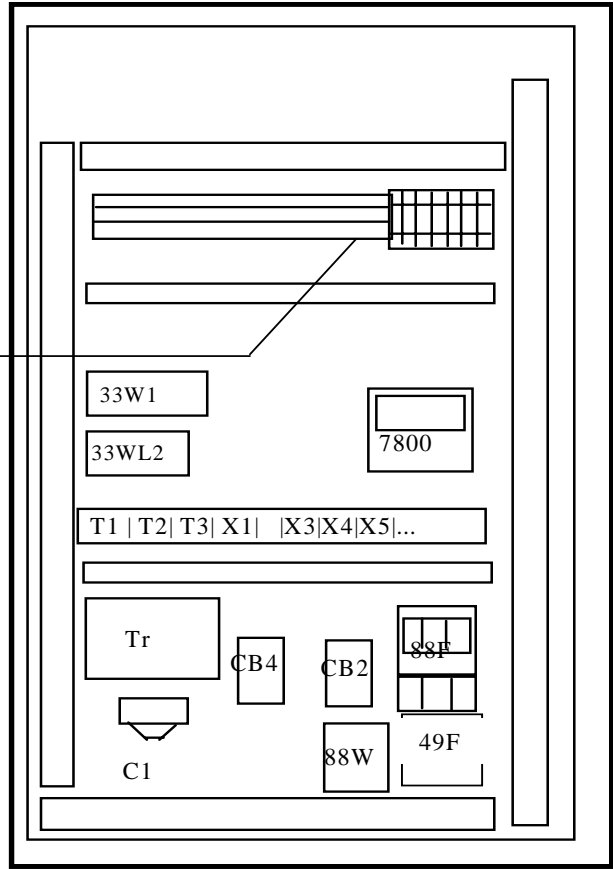

LX/LXL-50/100 Boiler Control Box Layout

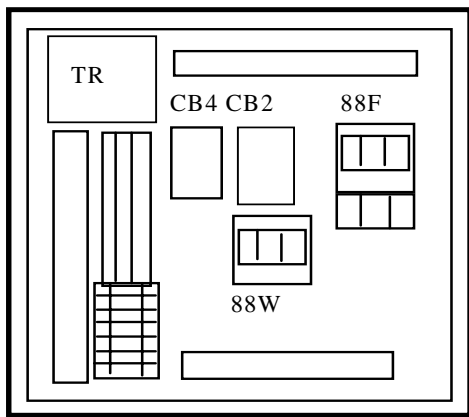

LX/LXL-150/200,300 Junction Box

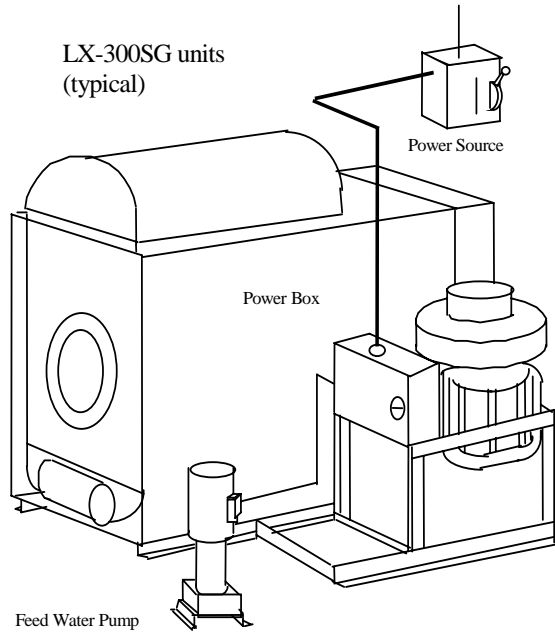
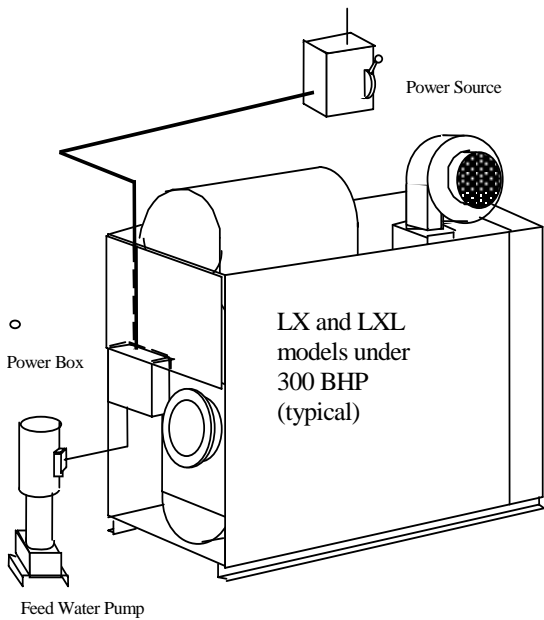

## SECTION 4 OPERATION

**DANGER:** All cover plates, enclosures and guards must be in place at all times, except during maintenance and servicing.

**CAUTION:**

- This is a shop tested, assembled and fully packaged boiler. Each unit and assembly has been well adjusted at the factory. It is very important not to make any adjustments without first consulting your nearest authorized MIURA dealer.
- Daily water analysis should be performed to see if additional treatment is needed. Use a tester of 1 PPM or less sensitivity.

**NOTE:** See MIURA XJ1 manual for detailed operation of the control panel.

### 4.1 PREPARATION BEFORE

Check the following **everyday** before boiler start-up:

- a) Make sure all gauges are operating correctly.
- b) Make sure there is water in the feed water tank (hotwell or deaerator).
- c) Make sure the boiler water is conditioned (for instructions on checking for soft water, refer to your water softener instruction manual).
- d) Make sure there are chemicals in the chemical feed tank.

### 4.2 START-UP

**CAUTION:** The following start-up routine must be followed in sequence.

- a) Open all feedwater inlet valves.
- b) Open the main gas valve of the select fuel and check that the required gas pressure (3-5 PSIG) is available. For dual fuel boiler, close the main gas valve of the fuel not being used.
- c) Turn the power source on. The "OPERATION" switch on the control panel will illuminate. The display on the panel will show "DISABLE" and steam pressure.
- d) Make sure the manual blow-off valves are closed.
- e) Turn the "OPERATION" switch to "ON" and the display on the panel will show, "ENABLE". The feedwater pump will also start automatically if the water volume is low.
- f) Once the feedwater pump has stopped, push the "COMBUSTION ON/OFF" button. After a pre-purge cycle (for about 10 sec.), combustion will begin automatically.

**NOTE:** If the secondary low water cut-off probe is dry, or boiler steam pressure is high, the display on the panel will show "STANDBY". If there is anything wrong with any of the "INTERLOCK" sensors, the display on the panel will show "ALARM" with the alarm condition and the alarm will sound after pushing the "COMBUSTION ON/OFF" button.

- g) The combustion sequence to full fire is as follows:
  - 1) Pre-purge
  - 2) Pilot gas ignition
  - 3) Pilot flame confirmation
  - 4) Low fire main burner ignition
  - 5) Low fire main burner confirmation
  - 6) Pilot gas shut-off
  - 7) High fire main burner (if required)
- h) When desired steam pressure is reached, slowly open the steam outlet valve.

### 4.3 BLOWDOWN AND BLOW-OFF

#### 4.3.1 AUTOMATIC SURFACE BLOWDOWN (STANDARD)

Blowdown systems are primarily operated “continuously” to control the concentrations of dissolved solids in boiler water. MIURA boiler automatic surface blowdown works on conductivity of water and evaporation rate.

#### 4.3.2 MANUAL BOTTOM BLOWOFF

**CAUTION: During Blowoff:**

- a) **Be sure the main steam valve is closed before beginning blowoff.**
- b) **Do not perform blowoff with steam pressure over 30 PSIG unless the Blowoff piping is specifically designed for a higher pressure.**
- c) **Blowoff the boiler on start-up rather than just after shutdown whenever possible. This will maintain boiler chemicals and pH in boiler while it is shutdown. In addition, do not manually blowoff during operation. Manual Blowoff during operation may result in boiler shut down due to low water content.**
- d) **Since the number of full blowoff is dependent upon running hours and water quality in your area, please follow the advice of the nearest MIURA distributor or water treatment representative.**

Blowoff systems are operated intermittently to remove accumulated sediment from the boiler and/or piping, or to lower boiler water level in a rapid manner. **It is recommended that blowoff be performed daily just after start-up:**

- a) Close the main steam valve, raise the steam pressure to 1.5 - 2.0 Kg/cm<sup>2</sup>G (20 - 30 PSIG), (for LXL-type, raise the pressure to 0.7 - 1.0 Kg/cm<sup>2</sup>G (10 - 15 PSIG)), then push the “COMBUSTION ON/OFF” button. Combustion will stop and post-purge will begin. Turn the “OPERATION” switch to “OFF” after post-purge.
- b) Open the blowoff valves slowly and begin blowoff.
- c) Since the frequency of full Blowdown is dependent upon running hours and water quality in your area, please follow the advice of the water treatment representative.
- d) Continue the blowdown until the boiler is completely dry. This will ensure all sludge is removed. Complete draining of the MIURA boiler is not dangerous to the boiler. Once blowoff is complete, close the blowoff valves and repeat start-up routine in Section 4.2.

- e) When required steam pressure is reached, **slowly** open the main steam valve.

### 4.3.3 AUTOMATIC BOTTOM BLOWOFF (OPTION)

This is optional equipment and is only recommended when the boiler feedwater **has no hardness** and the silica is removed. The water must also be free of any thick sludge and a non-precipitation hardness modifier is used. Phosphate treatment is **not recommended**. Please discuss this further with your water treatment supplier of chemicals.

- a) The optional automatic blowoff valve will reduce the manual full blowoff sequence of the boiler to up to two weeks depending on water conditions.
- b) The bottom blowoff valve automatically opens for 30 seconds every 60 seconds of High Fire combustion time. The frequency of blowoff is determined by the quality of the feedwater. The feedwater quality to be maintained must be less than 0.5 PPM of hardness. Also the **boiler water quality** must be maintained, so that the boiler water conductivity is kept below 4,000 mmhos. The automatic bottom blowoff valve will not open unless the feedwater pump is OFF and water volume is normal.

**DANGER: The optional automatic blowoff valve and piping arrangement must be secured properly, as this line will be under full operating steam pressure.**

**CAUTION: A full manual blowoff must be conducted at least once every 2 weeks, to prevent scale build up.**

## 4.4 SHUTDOWN

**CAUTION: The following shutdown routine must be followed in sequence.**

- a) Push the “COMBUSTION ON/OFF” button. Combustion will stop and post-purge will begin.
- b) Once post-purge has finished, turn the "OPERATION" switch to "OFF" position.
- c) Close all feed water inlet and outlet valves.
- d) Close the fuel valves.
- e) Turn off the main power supply to the boiler.
- f) After prolonged shutdown, follow start up procedure to restart the boiler.

## 4.5 CAUTIONS DURING OPERATION

**DANGER: The following points MUST be followed to avoid damage or injury.**

- a) Always open the main steam outlet valve **slowly** to prevent carryover and water hammer.
- b) If there is a misfire or flame failure, locate the cause of the problem, (as discussed in Section Troubleshooting) fix it, push the “COMBUSTION ON/OFF” button then push the reset

button on the display and re-start the boiler. If the same problem persists, shut the boiler down and call the nearest MIURA representative or distributor.

- c) Whenever fuses need replacing, use only specified ratings. When replacing a circuit breaker or magnetic contactor, ensure that trip settings are set correctly on the new component.
- d) If the circuit breaker tripped, check it, and then reset it. In this case, re-test the low water interlock by blowoff as described in the section of blowoff. If the alarm does not sound when tested, see Troubleshooting Section. If the circuit breaker trips again, shut down the boiler. Call an electrician or the nearest MIURA representative or distributor.
- e) Proper balance of gas and airflow is needed to assure complete combustion and optimum efficiency. Adjust the airflow as needed. MIURA recommends a combustion tune up every three to four months to maintain optimum efficiency due to air temperature and humidity changes every season. Contact your nearest MIURA representative or distributor to adjust air flow.
- f) Do not change the setting on the high-pressure limit or over heat protection.
- g) When unsure of any boiler trouble, shut down the boiler, turn the power source off and contact your nearest MIURA representative or distributor.
- h) **If you smell gas, immediately shut down the boiler, turn off all power sources, and close all main gas valves.** Immediately locate and repair the source of leak, and contact your gas company and then a MIURA representative.
- i) Be careful when you take a sample of water from the boiler. Please be sure to open the valve very **slowly**. A water sample cooler is strongly recommended.
- j) **Do not re-light pilot or start burner with the combustion chamber full of gas or with a very hot combustion chamber.**
- k) **In an emergency, push the "COMBUSTION ON/OFF" button to stop combustion and close the GAS VALVE first, then cut out the main power supply to the boiler.**
- l) As sludge or dirt may possibly affect the performance of the automatic solenoid blowdown, it should be checked periodically to confirm proper operation.
- m) Do not close the feed water valves to the economizer (if applicable). Only in the event of an economizer problem, should the bypass valve be used.
- n) If frequent Low Water Level alarms occur, clean all Water level probes and the feed water strainer prior to calling for service on the boiler. Dirty probes cause over 90% of the Low Water Alarms.
- o) For dual fuel boilers, make sure to close the main gas valve of the fuel that is not in use, before starting the boiler. Also check to make sure neither actuator of that gas train is open during main combustion.

## **4.6 SAFETY ATTACHMENTS**

### *4.6.1 LOW WATER VOLUME CUT-OFF*

If the water volume, for any reason, falls below the pre-determined water volume, combustion will immediately be stopped; a warning alarm will be activated. The display will read, "ALARM" and "LOW WATER LEVEL".

After complete blowdown of the boiler, all the red lights on the floatless switches will be off. With the main power turned on at the boiler and the "OPERATION ON/OFF" switch "ON", the

feedwater pump will start. After a few minutes, the red LED of floatless switch #33WL1 will illuminate. Then the red LED of the floatless switch #33WL2, will come on. The Feed water pump will continue running until the required water volume for start up is met. At this point, the feed water pump will stop. If the red LED of any floatless switch does not come on in the above sequence, please check the electrodes and wiring to the electrodes.

Probe	Wire	Switch contact	Function
Longest on LVC	E1 (red)	33WL1	Low water cut off
Medium on LVC	E2 (white)	CPU (5)	Pump control
Shortest on LVC	E3 (blue)	CPU (7)	Pump control
Longest in boiler	E4 (orange)	33WL2	Secondary LWC
Shortest in boiler	E5 (brown)	CPU (7)	Secondary control
In separator	E6 (gray)	33WH	Option High water
In return pipe	E8 (purple)	CPU (12)	Conductivity control

For testing the Low Water Volume Cut-off, open the ball valve at the bottom of the LVC and allow time for the steam pressure to force the water out of the LVC (about 5-10 seconds). When the low water cut-off probe loses contact with the water, the boiler will shut down, the alarm will sound and the XJ1 Microcomputer will display “LOW WATER CUT-OFF”.

#### 4.6.2 OVER HEAT MONITOR TEMPERATURE

If the temperature of the overheat thermocouple on the water tubes should, for any reason, rise above the pre-set temperature, the XJ1 Microcomputer will shut down the boiler, activating the alarm. The display will also show "HIGH W TUBE TEMP".

For testing these functions, use the “Set Clock” menu. Record the present setting temperature then set it to lower than the tube temperature. It will shut down the boiler when the tube temperature reaches the new preset value. We suggest changing only the hundreds value. After testing, do not forget to reset to original setting or the boiler will not run.

#### 4.6.3 SCALE MONITOR TEMPERATURE

If the temperature of the scale monitor thermocouple on the water tubes should, for any reason, rise above the pre-set temperature, the XJ1 Microcomputer will shut down the boiler, activating the alarm. The display will also show “SCALE WARNING”. Note that there are two different settings for the scale monitor alarm. One setting is used during High-fire and other during Low-fire. The XJ1 Microcomputer will wait 40 seconds after change in firing rate to evaluate the current tube temperature against the alarm set point. It also adjusts the alarm set point internally based on boiler steam pressure. **Do not change these settings from the factory numbers.**

For testing these functions, use the “Set Clock” menu. Record the present setting temperature then set it to lower than the tube temperature. It will shut down the boiler when the tube temperature reaches the new preset value. We suggest changing only the hundreds value. After testing, do not forget to reset to original setting or the boiler will not run.

**CAUTION:** Should the high temperature alarm ever be activated, immediately contact your nearest authorized MIURA representative and chemical company. DO NOT restart the boiler or change the setting without written authorization or pressure vessel may be severely damaged.

#### 4.6.4 HIGH PRESSURE LIMIT CUT-OFF SWITCH

If the boiler pressure should, for any reason, rise above the pre-set pressure (Max. 170 PSIG for LX, 15 PSIG for LXL and 300 PSIG for LXH), the High Pressure Limit switch will be activated, the boiler will shut down, and the alarm will activate. The display will show "ALARM" and "EMERGENCY STOP".

If the boiler shuts down due to high pressure, you need to press the reset level on the pressure switch to restart the boiler. Please check the pressure transducer and setting of the XJ1 Microcomputer as well as the Control Pressure switch for any malfunction or wrong setting. The Control Pressure switch should have a lower setting than the High Pressure Limit switch, and the XJ1 Microcomputer should have a lower setting than both steam pressure switches.

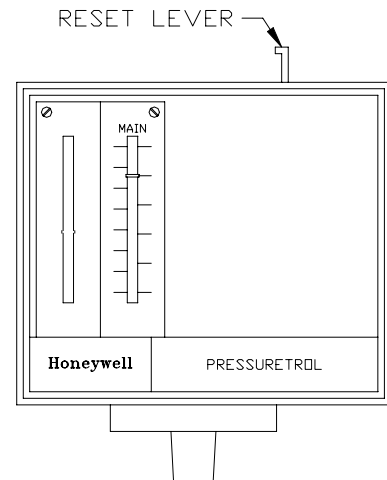

For testing the High Pressure Limit Switch, set it lower than the XJ1 Microcomputer setting. It will shut down the boiler when the boiler pressure reaches the set pressure. Be sure to set it back to the original setting and reset the High Pressure Limit Switch.

#### 4.6.5 MISFIRE

If ignition is not achieved after the ignition period, burner operation will immediately be stopped. After a purge cycle, the safety switch of the Flame Safeguard will be activated, a warning alarm will sound, and the display will show "ALARM" and "FLAME FAILURE".

For testing the Flame Safeguard, close the pilot gas valve, and then start the boiler. Misfire will occur after first or second attempt for pilot. After testing, do not forget to open the pilot valve and reset the XJ1 Microcomputer.

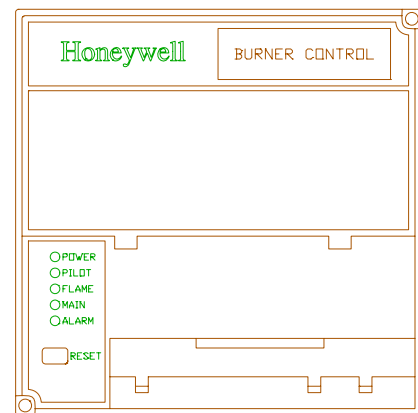

#### 4.6.6 FALSE SIGNALS

Should there be any false signals emitted during ignition, pre-purge, or should pre-purge timing be off, the safety switch of the Flame Safeguard will be activated, the boiler will be shutdown, and a warning alarm will sound. The display will show the reason for interlock.

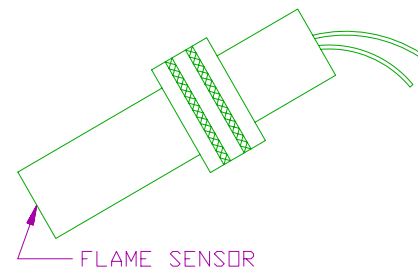

For testing, during pre-purge, take the flame eye out and point it to a flame (of a cigarette lighter for example). The boiler will continue to purge, but the pilot will not come on. After testing, do not forget to put the flame eye back to its original position and reset the XJ1 Microcomputer.

#### 4.6.7 POWER OVERLOAD

Overload or short-circuiting of the blower motor will result in boiler shutdown, activating the warning alarm, and the display will show "ALARM" and "AIR PRESS FAULT". Some motors have an internal stator winding thermal overload feature. If thermal overload – 49F has not tripped in the boiler control panel, operation will not resume until the blower motor has cooled down.

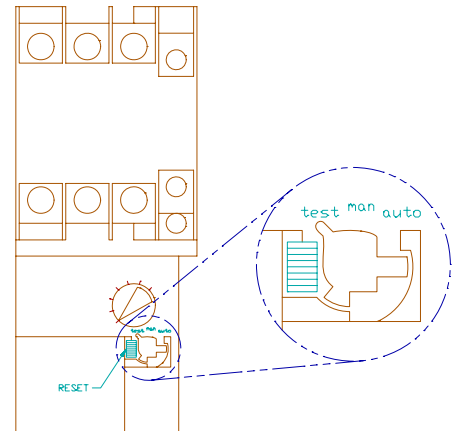

#### 4.6.8 DAMPER MICRO-SWITCH

If damper should for any reason stay in the wrong position, the micro-switch on the damper will shut down the boiler, activating the alarm and the display will also show "ALARM" and "AIR PRESS FAULT".

#### 4.6.9 AIR PRESSURE

If the air pressure in air duct, for any reason, falls below the predetermined pressure, combustion will be immediately be stopped and a warning alarm will sound. The display will also show "ALARM" and "AIR PRESS FAULT".

For testing, turn the setting of overload protector #88F to "TEST". During combustion, press and hold the reset button of overload protector #88F. The blower will slow down to a stop, as there will not be enough airflow and the boiler will shut down. Release the reset button, set overload protector #88F back to manual and reset the boiler.

**NOTE: MIURA recommends installing optional air filter box to prevent the burner from dust.**

#### 4.6.10 FUEL GAS PRESSURE

When the "COMBUSTION ON/OFF" button is pushed prior to combustion, if there is not enough gas pressure, the burner cannot ignite and the warning alarm will sound. If, during the process of boiler operation, gas pressure falls below the required range, combustion will stop, and the alarm will sound. In addition, the display will show "ALARM" and "LOW GAS PRESS" or "HIGH GAS PRESS".

For testing the Low Gas pressure switch, close the main gas valve upstream of the gas train during combustion. Boiler will shut off because

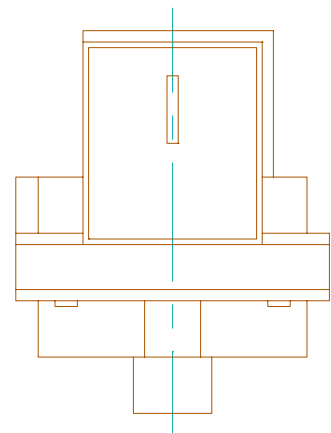

of low gas pressure and Misfire. After resetting the XJ1 Microcomputer, the boiler will not restart because of low gas pressure until the main gas valve is opened again.

For testing the High Gas pressure switch, close the main gas burner inlet valve down-stream of the gas train during combustion. Boiler will shut off because of high gas pressure and Misfire. After resetting the XJ1 Microcomputer, the boiler will not restart because of high gas pressure until the main gas valve is opened again.

## 4.7 WATER TREATMENT

**CAUTION: Check with your water treatment representative for details.**

**NOTE: Miura Boiler Co., Ltd. cannot be responsible for any problems encountered with the boiler due to unsuitable water treatment. Please contact a reliable water treatment company and follow their directions.**

### 4.7.1 PREVENTATIVE MAINTENANCE FOR EXTENDED SHUTDOWN

To prevent internal corrosion during periods of extended shutdown (7 days or more), the following must be done:

- a) Raise the boiler water pH level between 11-12 to reduce corrosion OR
- b) Drain the water and dry the boiler completely. Add an inert gas or a deoxidising agent.

Since the LX is a small water content, water tube boiler design, keeping the water in the boiler and raising the pH is the preferred preventative method. However, in places where freezing is a problem and shutdown is more than 7 days, it is preferred that the boiler be drained of all water. Contact your nearest MIURA representative or distributor for further details.

Finally, check to make sure all manual valves (water inlet, steam outlet, main & pilot gas,...) are closed tightly and turn off the main power supply to boiler during shutdown.

### 4.7.2 CARRYOVER

The MIURA Boiler is tested to produce steam with less than 0.25% moisture. This steam quality can be adversely affected by several factors.

1. Poor water quality: It can produce "carryover". The indications are foaming, priming and misting. Energy loss, fouling, blockage of components and corrosion will result. The LX-Series steam boiler has automatic surface blowdown equipment to minimize the concentration of solids during operation. However, daily manual blow down is necessary. Follow the recommendations of a reputable water treatment company to limit conductivity.
2. Over steam demand: Exceeding the steam production rating of the boiler can overwhelm the moisture separator and allow boiler water carry over.
3. Over firing: Exceeding design heat input rate would result in steam production exceeding the capacity of the boiler and result in boiler water carry over. This condition will also shorten the life of the boiler and could cause tube damage that would not be covered by warranty.

4. Steam Demand surges: This is the normal cause of boiler water carry over for all types of boilers. This situation occurs when there is a sudden demand for steam that can be caused by types of equipment that use an on-off steam control system. This situation can be illustrated by a steam load that normally draws 25% boiler capacity and then “steps up” to 100% boiler capacity very quickly. This results in “flashing” of the water in the boiler as steam pressure drops and a momentary steam draw rate that is above nominal capacity. This “Flashing” can carry boiler water with it. This type of carry over is easily corrected by shutting the steam outlet valve and then opening it 1½ turns. This does not affect the steam production capacity of the boiler. The effect is to restrict the rate of change of the steam flow and will stop carry over caused by “Surging”.
5. Water level control system faults: Such as an open circuit on the water level probes. This is extremely rare.
6. Flooded Boiler: Boiler water level above normal when boiler starts. In some situations, the boiler may “siphon” water out of the feed water tank. Usually this occurs if a boiler is turned off and the isolation valves are not shut on the feed water supply.
7. Steam Pressure: Operating the LX boiler at less than 70 PSI steam pressure.

#### 4.7.3 BOILER MAKE UP WATER

**CAUTION: Proper water treatment MUST be used from the time the boiler is first operated. MIURA has no warranties to cover damage due to poor water treatment and failure to maintain these specifications listed below.**

#### MIURA MAKE-UP WATER MAINTENANCE CHECK

**In order to keep your LX Series running in top condition, be sure to check the following daily:**

- a) CHEMICAL FEED PUMP
  - i. Proper chemical feed.
  - ii. Sufficient liquids to properly dissolve chemicals.
  - iii. No air in the chemical feed pump or lines.
- b) WATER SOFTENER
  - i. Boiler Make-up water is completely soft (use a test kit sensitive to less than 1.0 PPM).
  - ii. Make sure the water softener timer or softener flow meter is working everyday.
  - iii. Make sure the by-pass valve is closed and inlet and outlet valves are open.
  - iv. Make sure there is no hardening of the salt. In case of salt hardening or “bridging” break the salt into small pieces.
  - v. Make sure the polishing water softener is working properly.

#### STANDARD BOILER WATER SPECIFICATIONS FOR THE LX SERIES

The chemistry values given in table below are specific guidelines established by MIURA Boiler. Analysis is to be performed by the customer or a boiler water treatment company. MIURA Boiler recommends Polymer type treatment. Phosphate type treatment results in soft sludge that

is not water-soluble. Therefore, phosphate treatment results in higher solids and more frequent bottom blowoff to maintain water conductivity. Frequent bottom blowoffs reduce the boiler system fuel to steam efficiency. Bottom blowoffs can be reduced in quantity and frequency with Polymer type treatment chemicals.

ITEM		UNITS	BOILER WATER	MAKE UP WATER
pH (at 25°C)			11.0 - 11.8	7 - 9
Hardness	CaCO <sub>3</sub>	mg/L	-0.0-	-0.0-
Oxygen	O <sub>2</sub>	PPM		Below 0.5 PPM or temperature above 90°C
P Alkalinity	CaCO <sub>3</sub>	mg/L	150 - 600	
M Alkalinity	CaCO <sub>3</sub>	mg/L	250 - 800	
Sulfites	S <sup>-</sup>	PPM	Detectable	Detectable
Conductivity (at 25°C)		µS/cm	1,500 - 4,000	
Chloride	Cl <sup>-</sup>	mg/L	Below 400	Below 30
Silica	SiO <sub>2</sub>	mg/L	Below 250	Below 30
Iron & Manganese	Fe + Mn	mg/L	Below 1.0	Total below 0.5

**NOTE:** One of the most common causes of boiler damage is scale. Water hardness must be tested daily. The conventional method of testing water hardness is through manual testing. Results can vary due to sample and reagent amounts, personal interpretation, and lack of continuity in monitoring hardness. An optional MIURA Colormetry CMU-124H solves all these problems by offering an automatic monitoring system for sample water collection, chemical reagent injection, mixing and evaluation. With this option, MIURA boiler will also display a message “CAUTION – CHECK SOFTENER” whenever MIURA Colormetry CMU-124H detects hardness.

**NOTE:** MIURA controls the water volume of boiler by conductivity. Special care is required for conductivity of make up water that is less than 50 µS/cm. Contact MIURA for details.

## SECTION 5 MAINTENANCE

### 5.1 MAINTENANCE & INSPECTION SCHEDULE

In order to maintain the high efficiency and to prevent costly breakdowns of your LX Series, perform the following maintenance and cleaning:

MAINTENANCE ITEMS	EVERY DAY	EVERY 3 MONTH	AS NEEDED	CHECK POINTS	REMARKS
Make-up Water	☺			Is water soft?	Scale
Full Blow-off	☺			Refer to Blowdown and Blow-off Section	Carry-over, sludge, scale
Low Water Cut-off	☺			Refer to Low Water Volume Cut-off Section Check electrode, wire...	For overheat protection
Gas Pressure	☺			Check gas pressure gauge needle for any abnormalities	Poor Combustion
Combustion Conditions	Visual	Tune up by analyzer		Check the combustion sound and flame color	Cause of misfire
Boiler Inside Inspection (upper & lower holes)		☺		Check for scale and sludge	Overheating, pitting
Windbox flange bolts		☺		Check for tightness	Cause of flue gas leakage
Air Duct		☺		Check the air leakage	Cause of poor combustion
Damper setting bolts		☺		Check for tightness	Cause of poor combustion
Damper motor & damper limit switch		☺		Check coupling & operation	Cause of poor combustion
Pilot burner condition and combustion		☺		Check electrode wear & ceramic condition	Cause of poor combustion
Water Volume Controller, water controller rods		☺		Clean with sandpaper (replace electrodes every year)	For overheat protection
Strainer			monthly	Clean the inside	Cause of low water
Feedwater Tank			☺	Clean the inside	Blocked feedwater
Electrical wiring			☺	Check for loose wires	
Pressure Gauge			☺	Compare zero point to pressure gauge	Unsuitable operation
Check blower cover			☺	Clean fan cover	Poor combustion
Burner Element			note 1	Dust on flame burner	Cause of poor combustion

Notes:

1. The burner element should be cleaned at least once per year in order to prevent a build-up of particles on the burner element surface. It is important to keep the burner element surface clean to prevent poor combustion. All particles should be removed from the burner element surface using compressed air and/or vacuum. This cleaning should be done by taking off the wind box cover and do NOT remove the burner element to avoid damaging the fire barrier. Contact MIURA representative if burner element requires service.

2. This is a basic maintenance schedule. If the fuel or water is of exceptionally poor quality, maintenance checks will naturally increase. Compare the water quality with our standards and adjust the schedule accordingly.
3. Electric motors are pre-lubricated at the factory and do not require additional lubrication at start up. Motors with grease fittings should only be lubricated with lithium-base grease at the time intervals given in the table below:

TYPE OF SERVICE	FREQUENCY OF GREASING
Seasonal (Motor/Boiler is idle for more than 6 months)	Yearly
Intermittently (normal daily operation of Boiler)	Semi-annually
Continuous	Quarterly

Do not over grease the bearings. Over greasing will cause increased bearing heat and can result in bearing and motor failure. Follow instructions on the motor nameplate.

**The battery in the XJ1 Microcomputer should be replaced as soon as possible if the display shows “REPLACE BATTERY”.**

It is recommended to replace the battery every 3 years.

- a) Turn off the power supply.
- b) Open CPU panel covers.
- c) Remove the battery from holder and remove the connector.
- d) Insert the connector of a new battery immediately.
- e) Fit a compatible battery into the holder and replace the panel cover.

## 5.2 SPARE PARTS

After the end of the parts warranty, it is not necessary to order replacement parts from MIURA. One of our design advantages is the use of non-proprietary parts. The electrical control components and assorted valves may be purchased from any industrial part supplier.

The list below is not all-inclusive and in general is more than required. If the customer does not have a stand by Boiler or is some distance away from the service representative or simply desires to maintain a more comprehensive selection of spare parts, contact MIURA for a more customized list.

The customer is reminded that standard ground shipment of a Warranty Replacement Part is at MIURA Expense. Express shipping charges will be billed to the Customer. In addition, return of the defective part to MIURA must be done at Customer expense. If a Warranty Replacement defective part is not returned to MIURA the customer will be invoiced for the replacement sent. In addition, if the defective part failure is determined to NOT be a manufacturing defect the Customer will be invoiced by MIURA.

NO	PART NAME	PART NUMBER	LX-50	LX-100	LX-150	LX-200	LXH-200	LX-300	LXH-300
1	Damper coupling rubber assembly	Lovejoy 5/8" x 7/16" L070	1	1	1	1	1	1	1
2	Flame eye	Honeywell C7035A1031	1	1	1	1	1	1	1
3	Floatless switch	26A1BO-03	1	1	1	1	1	1	1
		16B1A0-00-10	1	1	1	1	1	1	1
4	Relay	LY-2, CSA, 120V	1	1	1	1	1	1	1
5	Magnetic contactor for blower.	CA7-85-19-120						208 V	208 V
		CA7-72-11-120						230 V	230 V
		CA7-60-11-120			208 V	208 V	208 V		
		CA7-43-11-120		208V	230 V	230 V	230 V		
	Manufactured by Sprecher	CA7-37-10-120		230 V				460 V 575 V	460 V 575 V
		CA7-30-10-120			460 V 575 V	460 V 575 V	460 V 575 V		
		CA7-16-10-120	208 V 230 V	460 V 575 V					
Quantity is one each, depending on boiler model and voltage	CA7-12-10-120	460 V 575 V							
6	Magnetic contactor for water pump	CA7-60-10-120							208 V
		CA7-43-10-120							230 V
		CA7-37-10-120					208 V		
	Manufactured by Sprecher	CA7-30-10-120					230 V	208 V	208 V
		CA7-23-10-120			208 V 230 V	208 V 230 V		230 V	460 V 575 V
		CA7-16-10-120	208 V 230 V	208 V 230 V			460 V	460 V	
		CA7-12-10-120	460 V 575 V	460 V 575 V	460 V 575 V	460 V 575 V	575 V	575 V	
Quantity is one each depending on boiler model and voltage									
7	Spark rod	SR100300	1	1	1	1	1	1	1
8	Level sensor *	Warrick 3H1C	1	1	1	1	1	1	1
9	Feed pump seal repair kit	LX-300 985201					1	1	1
		LX 985167 (Seal: 96455086 & gasket: 96455090)		1	1	1			
	CR2/4/8 (CR1/3/5)	LXL 985167 (Seal: 96455086 & gasket: 96455090)	1	1	1	1			
10	Thermocouple	Type K ungrounded	1	1	1	1	1	1	1
11	Compression Fitting	CF 100000 (for thermocouple)	1	1	1	1	1	1	1
12	Burner element packing	FB 100200 (not pre-cut) (issue quantity is sq. ft.)	2	2	2	2	2	3	3

The above listed spare parts are not initially included with the boiler.

\* This is the longest level sensor probe. This probe may be shortened if necessary to replace probes in the LVC.

### 5.3 TROUBLESHOOTING

PROBLEM	ITEM TO CHECK	CAUSE	REMEDY	*
1. No light in "OPERATION" switch.	a) Main power switch on?		Turn main power breaker on	
	b) Main power fuse tripped?	Short circuiting	Locate cause of short circuit, repair and replace fuse	
	c) Circuit breaker broken OR wires loose?		Replace circuit breaker OR tighten terminal wires	*
2. No display on panel.	a) No display inside control box?	Short circuiting OR circuit breaker tripping	Locate cause of short circuit and repair/reset circuit breaker	
	b) Still display inside control box?	Loose wires OR broken display Wrong direction connect	Tighten terminal wires OR replace display Reconnect cable	*
3. The feed water pump does not work even though the pre-set water volume is not yet reached	a) Make sure water volume rods are not bent	Rod acting like ground to earth	Straighten rod	
	b) Retainer cracked?	Insulation failure	Replace	
	c) Microcomputer broken?		Replace	*
	e) Feedwater pump motor stopped by overload?	Feedwater pump motor broken	Replace	*
	f) Current running through pump motor?	Wire is loose	Fasten wires securely	
4. The feedwater pump runs but water is not being fed into boiler OR amount of feedwater is too small.	a) Main feedwater valve and feedwater stop cock open?		Open all feedwater valves completely	
	b) Water in feedwater tank?		Add water	
	c) Did you completely release air from air release plug?	Air in feedwater pump has stopped water from flowing	Release air completely	
	d) Check direction of rotation of pump motor		Reverse the wires for the feedwater pump	
	e) Water strainer plugged?		Clean the strainer	
	f) Not any of the above.	Pump capacity is too low	Change the pump	*
5. The feedwater pump keeps running even after pre-set liquid volume is reached.	a) Retainer cracked?	Retainer is broken	Replace retainer	
	b) Are nuts on upper part of retainer loose?	Wires not connected properly	Adjust wires and tighten properly	
	c) Liquid volume sensor rods dirty?	Dirt and scale prevent conduction	Clean with sandpaper OR other abrasive material	
	d) Micro-Computer broken?		Replace	*
6. Even after "OPERATION" switch turns "ON" and "COMBUSTION ON/OFF" button is pushed, boiler doesn't start.	a) No alarm and display shows "STAND-BY"?	Sufficient steam pressure	Drop steam pressure to automatically start boiler	
		MI control set other boiler at higher priority	Change priority or set MI control to manual	
		Low bubble rod did not detect water	Check electrode, pump ...	
	b) Alarm on? Check problem shown on display		Fix problem and reset boiler	

PROBLEM	ITEM TO CHECK	CAUSE	REMEDY	*	
7. Combustion will not start.	a) Main gas cock open?	No gas for combustion	Open main gas valve		
	b) Damper setting adjusted?	Insufficient air flow	Adjust to proper setting		
	c) Fan cover clean?				
	d) Main gas valve open?	Loose wiring OR faulty gas valve	Tighten wires OR replace		
	e) Spark rod working properly?		Loose wire	Tighten wires	
			Faulty cord on spark plug	Replace spark plug cord	*
		Carbon on spark rod	Clean up		
f) Ultraviolet flame eye detecting flame?		Faulty spark plug	Replace	*	
		Flame eye wire is loose OR faulty flame eye	Tighten wires OR replace	*	
8. There is ignition but flame dies out.	a) Main gas cock open?	No gas for combustion	Open gas cock		
	b) Incorrect gas pressure OR damper setting?		Adjust to proper setting?		
	c) Flame eye sensing flame?	Faulty flame eye or loose wire	Replace UV sensor or tight wire		
9. Too much smoke from the chimney. Misfire becomes problematic.	a) Gas pressure is too high	Too much gas for combustion	Set accordingly		
	b) Damper setting off OR is retainer loose?	Not enough air	Set accordingly OR replace damper motor	*	
10. Steam is escaping from the safety valve.	a) Check the "High Limit" switch	Limit switch is not set properly OR is broken	Adjust the limit setting OR replace	*	
	b) The pipe leading to the steam pressure sensor plugged?		Remove and clean the pipe		
	c) Check safety valve setting	Improper setting	Replace if needed	*	
11. Strange sound occurs on high fire.	a) Gas pressure is low	Too much air	Adjust		
	b) Is the damper adjusted properly?				
12. Flames die out when going from high fire to low fire.	a) Check the damper position	Too much air	Adjust		
	b) Check the gas pressure	Not enough gas			
13. It cannot go from low fire to high fire	a) Check the damper position	Insufficient air	Adjust		
	b) Check the gas pressure	Insufficient gas pressure	Adjust		
	c) Check the two stage valve for high fire	Not enough gas for high fire	Replace and check electrical wiring	*	
	d) Check the air duct fixture	Air leakage	Tighten OR replace		
	e) Check the steam high-low pressure switch. Is the pressure side "ON"?	Incorrect wiring, OR it has reached current steam pressure setting			
14. Blower motor running but no ignition.	a) Check air pressure switch	Incorrect setting, broken, OR loose wiring	Replace, reset, OR tighten terminal contacts	*	
	b) Check blower rotation	Reversed rotation	Reverse wire		
	c) Check spark rod	Faulty	Replace	*	
	d) Check flame safeguard	Faulty	Replace	*	

\* ALWAYS contact your nearest MIURA representative.

# 5.4 FLOW CHART OF LX(L) SEQUENCE OPERATION

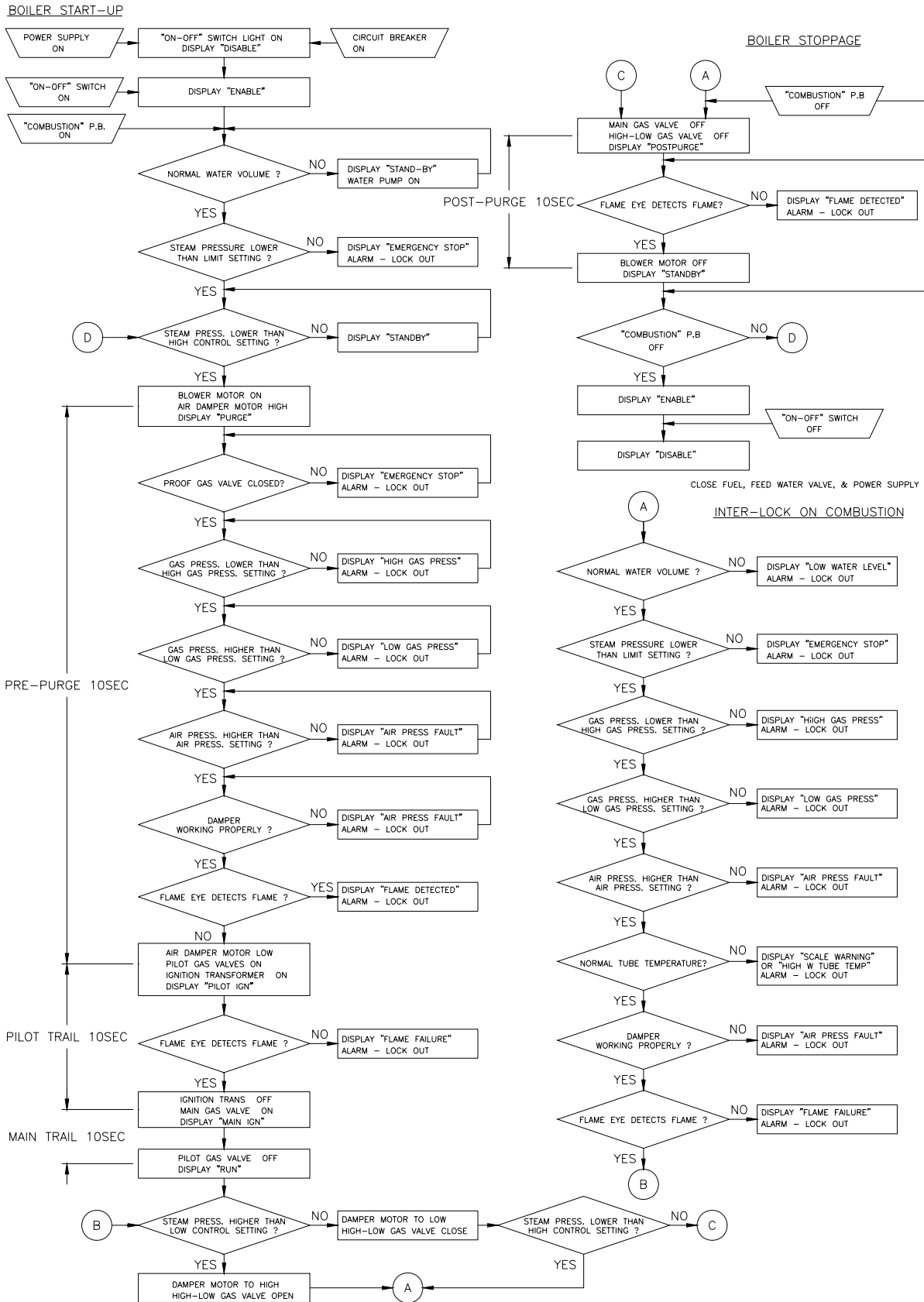

DISTRIBUTOR INFORMATION	
NAME	
ADDRESS	
TELEPHONE	
FAX	
DATE OF INSTALLATION	
BOILER MODEL	

# MIURA BOILER OFFICES

## WWW.MIURABOILER.COM

### ATLANTA:

1900 THE EXCHANGE SE, SUITE 330  
 ATLANTA, GA  
 30339-2022  
 PHONE: (770) 916-1695  
 FAX: (770) 916-1858  
[ATLANTA@MIURABOILER.COM](mailto:ATLANTA@MIURABOILER.COM)

### CHICAGO:

600 NORTHGATE PARKWAY, UNIT M  
 WHEELING, ILLINOIS  
 60090-3201  
 PHONE: (847) 465-0001  
 FAX: (847) 465-0011  
[CHICAGO@MIURABOILER.COM](mailto:CHICAGO@MIURABOILER.COM)

### LOS ANGELES:

1945 SOUTH MYRTLE AVE.  
 MONROVIA, CALIFORNIA  
 91016-4854  
 PHONE: (626) 305-6622  
 FAX: (626) 305-6624  
[LA@MIURABOILER.COM](mailto:LA@MIURABOILER.COM)

### NEW YORK:

411 Hackensack Avenue, 9<sup>th</sup> Floor  
 Hackensack, New Jersey  
 07601  
 PHONE: (201) 592-1260  
 FAX: (201) 592-1262  
[NEWJERSEY@MIURABOILER.COM](mailto:NEWJERSEY@MIURABOILER.COM)

### MIURA BOILER FACTORY:

8 COPERNICUS BLVD.,  
 BRANTFORD, ONTARIO  
 N3P 1Y4  
 PHONE: (519) 758-8111  
 FAX: (519) 758-5294  
[MIURASAL@BIS.ON.CA](mailto:MIURASAL@BIS.ON.CA)

### MISSISSAUGA:

6315 SHAWSON DRIVE, UNIT #17,  
 MISSISSAUGA, ONTARIO  
 L5T 1J2  
 PHONE: (905) 564-9199